

## INSTALLATION INSTRUCTIONS:

- FLEXIBLE SPRING-STEEL ARM SHIELDS
- ON/OFF MAGNET-BASE SHIELDS
- UNIVERSAL BALL & SOCKET SHIELDS
- RIGID-ARM MAGNETIC-BASE SHIELDS



*Flexible Spring-Steel Arm Shield*



*On/Off Magnet-Base Shield*



*Universal Ball & Socket Shield*



*Rigid-Arm Magnetic-Base Shield*

# SECTION 1 — FLEXIBLE SPRING-STEEL ARM SHIELDS

## Chip Shield Installation Instructions

### Exploded View of Flexible-Arm Shield

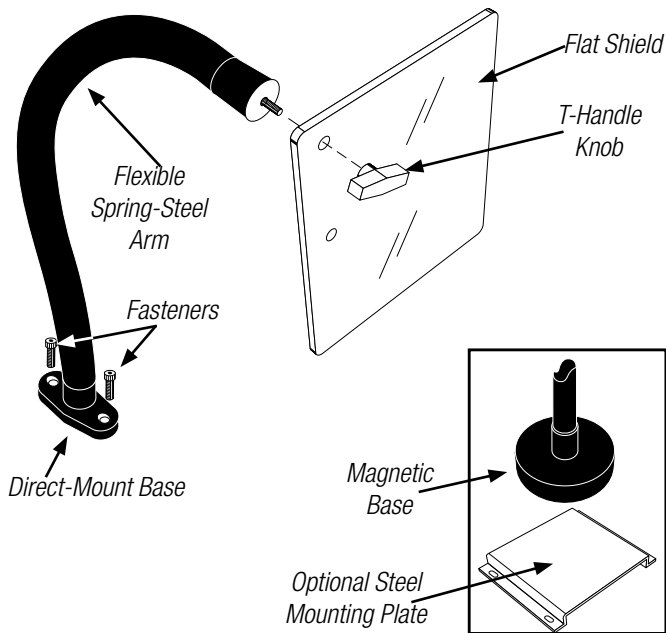

### Installation

1. Remove all packing material from the shield and the flexible arm. Remove the protective covering from both sides of the shield.
2. Using one of the holes in the shield, fasten the shield to the end of the flexible arm with the T-handle knob.
3. Determine the mounting location of the shield assembly.
4. Direct-mount base: Use the holes on the base to spot mounting holes where the base will be mounted. If using the socket-head cap screws, drill and tap two 1/4"-20 holes; if using the wood screws, drill small pilot holes to get the screws started. Be careful when drilling holes into the frame of a machine. Avoid internal components that could affect machine operation. Magnetic base: When mounting the shield assembly, the magnetic force should be strong enough to withstand movement of the shield. If an adequate flat, ferrous mounting surface is not available, an optional steel mounting plate (part No. FKT-1106) should be used. If the steel mounting plate is used, spot the mounting holes using the plate as a guide. Drill and tap four holes. Be careful when drilling holes into the frame of a machine. Avoid internal components that could affect machine operation.
5. Fasten/attach the base to the mounting location.
6. Bend the flexible arm and adjust the shield into the proper position for the application.

### Replacement Parts

Part No.	Description
KYF-036	12" Flexible Arm Only With Direct-Mount Base
KYF-037	18" Flexible Arm Only With Direct-Mount Base
KYF-057	24" Flexible Arm Only With Direct-Mount Base
KYF-038	12" Flexible Arm Only With Magnetic Base
KYF-039	18" Flexible Arm Only With Magnetic Base
KYF-058	24" Flexible Arm Only With Magnetic Base
CSAA-3	6" x 8" Flat Shield Only
CSAA-5	10" x 12" Flat Shield Only
CSAD-2	8" x 10" Concave Shield Only
CSAD-3	10" x 12" Concave Shield Only
KYL-012	30° Angle Shield (7" Front) Only
KYL-017	30° Angle Shield (103/8" Front) Only
KYL-018	90° Angle Shield Only
KYL-126	30° & 90° Angle Shield (103/8" Front)
FKT-083	T-Handle Knob
FKT-1106	Optional Steel Mounting Plate

# SECTION 2 —ON/OFF MAGNET-BASE SHIELDS

Chip Shield Installation Instructions

## Installation

1. Remove all packing material from the shield, flexible arm and magnet. Remove the protective covering from both sides of the shield.
2. Using one of the holes in the shield, fasten the shield to the end of the flexible arm with the T-handle knob.
3. Locate a ferrous surface to place on/off magnet. If no ferrous surface is available, an optional steel mounting plate (Part No. FKT-1106) can be used.
4. Turn magnet switch from “off” to “on”.
5. Bend the flexible arm and adjust the shield into proper position for the application.
6. **Caution:** the on/off magnet has a 200-lb holding force when on and can damage electronic devices if positioned too near them.

## Replacement Parts

Part No.	Description
KYF-062	12" Flexible Arm For On/Off Magnet-Base Shield
KYF-063	18" Flexible Arm For On/Off Magnet-Base Shield
KYF-064	24" Flexible Arm For On/Off Magnet-Base Shield
CSAA-3	6" x 8" Flat Shield Only
CSAA-5	10" x 12" Flat Shield Only
CSAD-2	8" x 10" Concave Shield Only
CSAD-3	10" x 12" Concave Shield Only
KYL-012	30° Angle Shield (7" Front) Only
KYL-017	30° Angle Shield (103/8" Front) Only
KYL-018	90° Angle Shield Only
KYL-126	30° & 90° Angle Shield (103/8" Front)
KYL-176	6" x 6" Flat Shield Only
KYL-177	18" x 6" Flat Shield Only
FKT-083	T-Handle Knob
FKT-285	On/Off Magnet Base Only With M12 Tap
FKT-1106	Optional Steel Mounting Plate

## On/Off Magnet-Base Shield

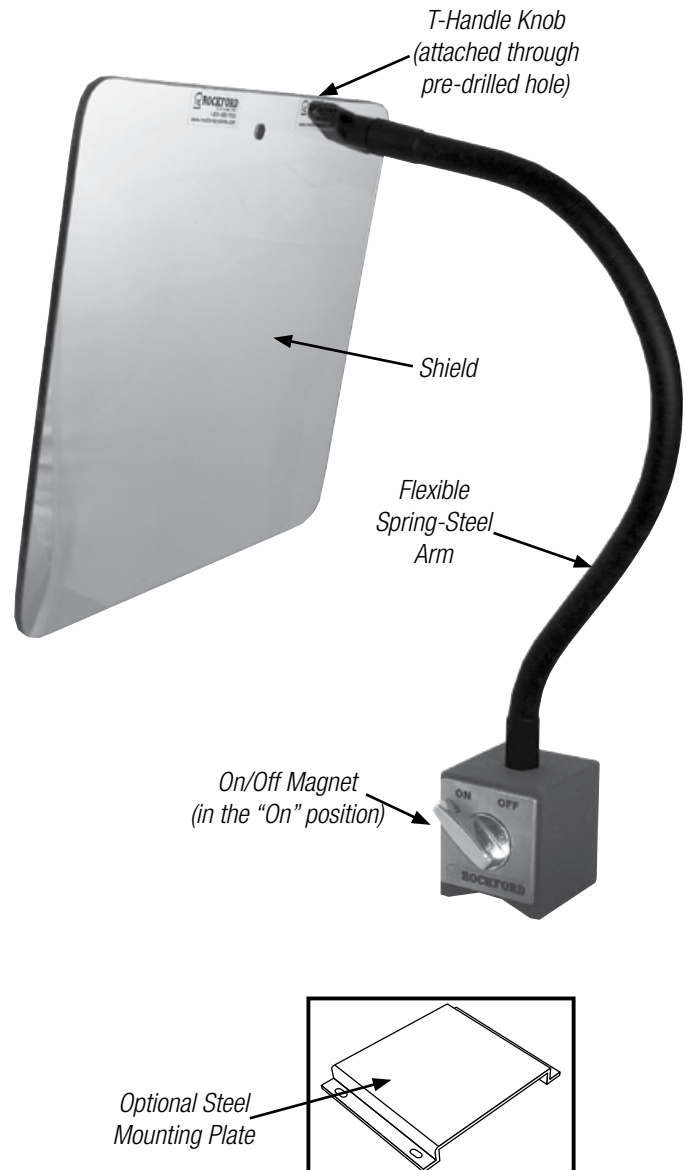

# SECTION 3 — UNIVERSAL BALL & SOCKET SHIELDS

## Chip Shield Installation Instructions

### Universal Ball & Socket Shield

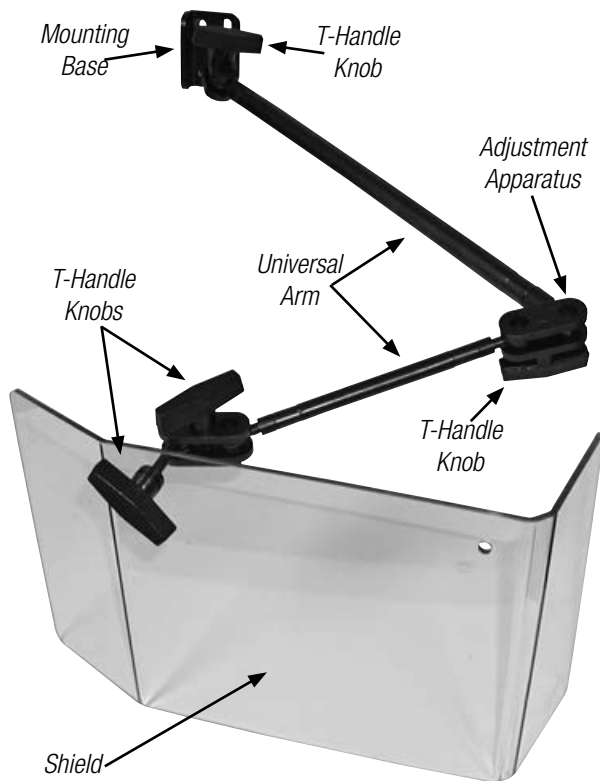

### Installation

1. Remove all packing material from the shield and the universal arm. Remove the protective covering from both sides of the shield.
2. Locate the mounting base.
3. Determine the mounting location of the base. The mounting location would normally be slightly above and behind the area where the shield will be used. It can be mounted to the frame or column on either side of the machine.
4. A special bracket may need to be fabricated when installing the universal arm because of the frame construction of the machine. Mounting should be rigid enough to withstand movement of the shield.
5. Locate the mounting holes using the universal arm bracket as a guide.
6. Use the mounting holes on the bracket to spot the holes. Drill and tap two holes using a 5/32" drill bit. Be careful when drilling holes into the frame of the machine. Avoid internal components that could affect machine operation.
7. Fasten the arm to the machine using two screws (not furnished).
8. Each shield has a hole in the corner(s) so the arm can be conveniently mounted on either side of the machine. Determine which hole on the shield will be used and attach the arm to it by tightening the provided T-handle knob.
9. Place the shield in the proper position for the application and tighten the T-handle knobs securely. The arm allows the shield to be moved easily into or out of position by using the T-handle knobs.

*NOTE: Do not overtighten the T-handle knobs as this could permanently damage the universal arm and prevent it from holding in position.*

### Replacement Parts

Part No.	Description
CSAA-3	6" x 8" Flat Shield Only
CSAA-5	10" x 12" Flat Shield Only
CSAD-2	8" x 10" Concave Shield Only
CSAD-3	10" x 12" Concave Shield Only
KYL-012	30° Angle Shield (7" Front) Only
KYL-017	30° Angle Shield (103/8" Front) Only
KYL-018	90° Angle Shield Only
KYL-126	30° & 90° Angle Shield (103/8" Front)
KYF-054	21" Universal Arm
KYF-055	31" Universal Arm
KYF-056	44" Universal Arm
FKT-083	T-Handle Knob

# SECTION 4 —RIGID-ARM MAGNETIC-BASE SHIELDS

## Chip Shield Installation Instructions

### Installation

1. Remove all packing material from the shield and the mounting assembly. If the shield is a flat shield, remove the protective covering from both sides of the shield.
2. Locate the magnetic base and the mounting plate for the shield.
3. Attach the cover to the magnetic base, using the furnished screw.
4. Locate the 8" base extrusion. Attach the magnetic assembly to the tapped end of this extrusion and tighten the screw.
5. For CBS-xC1B shields only: Locate the furnished washer, knob, and the 12" arm extension. Place the washer on the base-extrusion bolt. Place the bolt in the hole on the 12" arm extension. Attach the knob to the bolt and tighten.
6. Locate the second washer, the shield, and the second knob. Place the washer on the arm bolt. Determine which hole on the shield will be used and place the bolt through it. Attach the knob to the bolt and tighten.
7. Determine the mounting location of the base. If the steel mounting plate is required, follow steps 8 through 10. If not, go to step 11.
8. When mounting the shield, the magnetic force should be strong enough to withstand movement of the shield. If it isn't, the steel mounting plate should be used.
9. If the steel mounting plate is used, spot the mounting holes using the plate as a guide.

10. Drill and tap four holes. Be careful when drilling holes into the frame of the machine. Avoid internal components that could affect machine operation. Fasten the mounting plate to the machine using the four furnished screws.
11. If using the magnetic base, please note that the magnet is very strong. Determine the location for the base. Attach the base to the machine in the desired location.
12. Use the knobs to adjust the shield for proper positioning for the application.

### Replacement Parts

Part No.	Description
FKT-099	8" Base Extrusion
FKT-100	12" Arm Extension
FKT-083	T-Handle Knob
FKT-694	Magnetic Base
FKT-125	Cover for Magnetic Base
FKT-1106	Steel Mounting Plate
FSC-082	1½" Base Extrusion Bolt
FSC-081	¾" Arm Bolt
FSC-100	Magnetic Base Bolt
FKT-755	Nylon Washer
CSAA-3	6" x 8" Flat Shield Only
CSAA-5	10" x 12" Flat Shield Only
CSAA-7	14" x 16" Flat Shield Only
CSAD-2	8" x 10" Concave Shield Only
CSAD-3	10" x 12" Concave Shield Only

### Exploded View of CBS-xC1B Magnetic-Base Shield

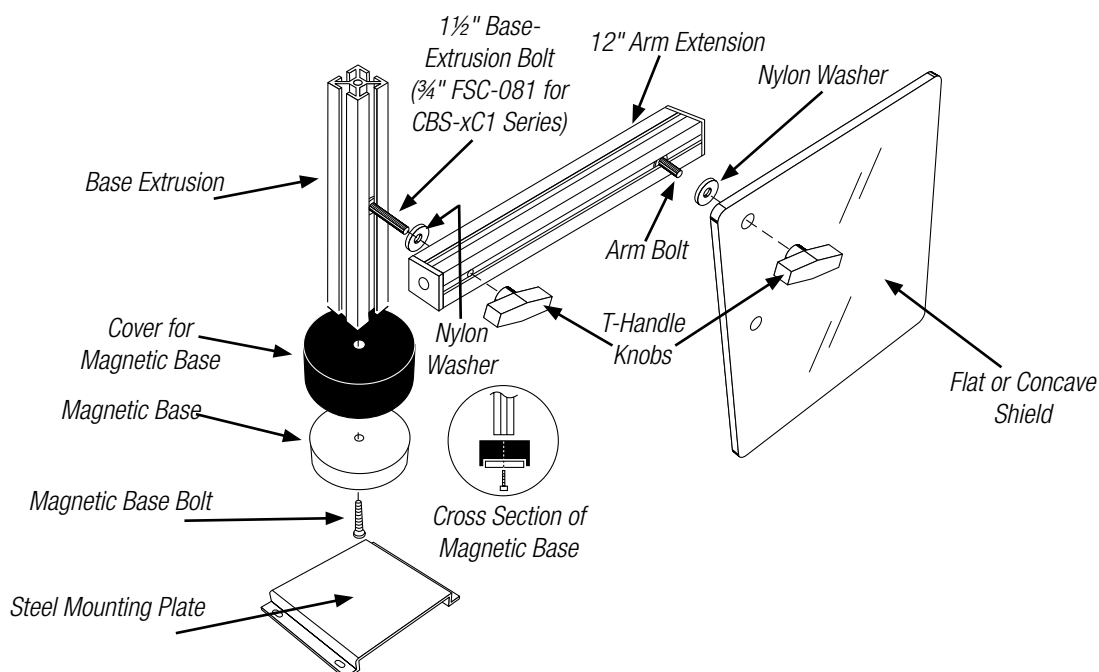

## SECTION 5 —OTHER CONSIDERATIONS

### Chip Shield Installation Instructions

## Using the Shield



The shield is intended to deflect objects such as chips (swarf) and splashing coolant. For protection, position the shield between the point of operation and the operator. Make sure it will not be hit by normal movements of the machine and its parts (machine table, chuck, rotating handles, etc.). During loading or setup of workpieces, the shield can be swung aside.

## Maintenance

These shields are made of polycarbonate which was selected for its strength and durability under impact. Although it will scratch if mistreated, it can be kept clear with appropriate care.

1. Remove coolant, chips, or debris periodically.
2. Using a clean sponge or soft clean cloth, wash with mild soap or detergent and lukewarm water.
3. Rinse well with clean water.
4. Hairline scratches or minor abrasions can be removed or minimized using a mild car polish such as paste wax. A wax coating also makes cleaning easier.

When many shields are used in a plant, spare shields can be kept on hand and exchanged periodically. The shields can be removed from the machines, carefully washed, and exchanged at a later date.

-  **Do Not** rub or wipe with dirty shop towels or scrape with a blade.
-  **Do Not** use gasoline, benzine, acetone, or carbon tetrachloride on the shield.
-  **Do Not** use cleaners or powders that contain abrasives or “dry rub” abrasive dust to remove coolant, lubricant, and chips.

## WARRANTY, DISCLAIMER AND LIMITATION OF LIABILITY

### WARRANTY

Rockford Systems, LLC warrants that this product will be free from defects in material and workmanship for a period of 12 months from the date of shipment thereof. ROCKFORD SYSTEMS LLC's OBLIGATION UNDER THIS WARRANTY IS EXPRESSLY AND EXCLUSIVELY LIMITED to repairing or replacing such products which are returned to it within the warranty period with shipping charges prepaid and which will be disclosed as defective upon examination by Rockford Systems, LLC. This warranty will not apply to any product which will have been subject to misuse, negligence, accident, restriction and use not in accordance with Rockford Systems, LLC's instructions or which will have been altered or repaired by persons other than the authorized agent or employees of Rockford Systems, LLC. Rockford Systems, LLC's warranties as to any component part is expressly limited to that of the manufacturer of the component part.

### DISCLAIMER

The foregoing Warranty is made in lieu of all other warranties, expressed or implied, and of all other liabilities and obligations on the part of Rockford Systems, LLC, including any liability for negligence, strict liability, or otherwise, and any implied warranty of merchantability or fitness for a particular purpose is expressly disclaimed.

### LIMITATION OF LIABILITY

Under no circumstances, including any claim of negligence, strict liability, or otherwise, shall Rockford Systems, LLC be liable for any incidental or consequential damages, or any loss or damage resulting from a defect in the product of Rockford Systems, LLC.



5795 Logistics Parkway, Rockford, Illinois 61109  
Toll Free 1-800-922-7533 (USA Only)  
Phone (815) 874-7891  
Fax (815) 874-6144  
Web Site: [www.rockfordsystems.com](http://www.rockfordsystems.com)  
E-Mail: [sales@rockfordsystems.com](mailto:sales@rockfordsystems.com)