



INSTALLATION MANUAL FOR ARM-TYPE AND OVERHEAD-TYPE RESTRAINTS



Photo 1 - Arm-Type Restraint

Photo 2 - Overhead-Type Restraint

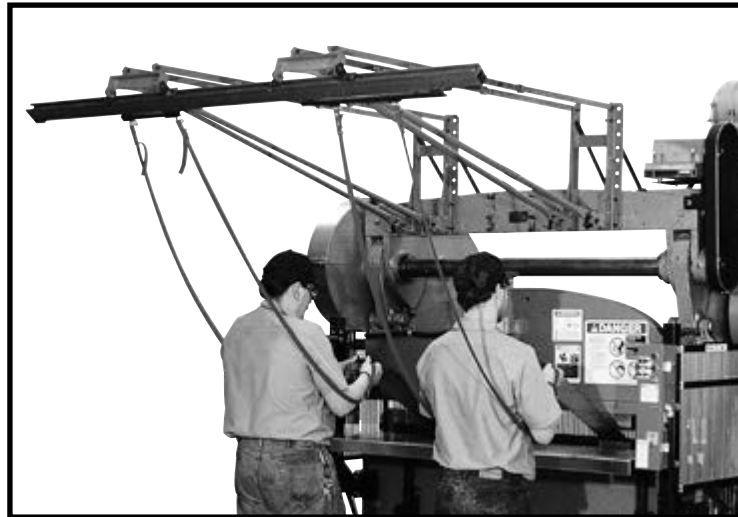

IMPORTANT: PLEASE REVIEW THIS ENTIRE PUBLICATION BEFORE INSTALLING, OPERATING OR MAINTAINING THIS RESTRAINT DEVICE.

TABLE OF CONTENTS

Arm-Type and Overhead-Type Restraints

SECTION 1—IN GENERAL	2-6	SECTION 4—INSTALLATION OF OVERHEAD	10-13
SECTION 2—RESTRAINT MEASUREMENT DATA	7	Single	10, 11
SECTION 3—INSTALLATION OF ARM-TYPE	8-9	Sliding.....	10, 12
Arm-Type Restraint Device Parts	8-9	Installation Steps	13
Steps to Follow Prior to Installation	9	SECTION 5—PRELIMINARY CONSIDERATIONS	14
		SECTION 6—ORDER FORM	15
		SECTION 7—RETURN MATERIALS FORM	15

SECTION 1—IN GENERAL

Safety Precautions

“ **DANGER** ” Danger is used to indicate the presence of a hazard which WILL cause SEVERE personal injury if the warning is ignored.

“  ” THIS SAFETY ALERT SYMBOL IDENTIFIES IMPORTANT SAFETY MESSAGES IN THIS MANUAL. WHEN YOU SEE THIS SYMBOL , BE ALERT TO THE POSSIBILITY OF PERSONAL INJURY, AND CAREFULLY READ THE MESSAGE THAT FOLLOWS.

Efficient and safe machine operation depends on the development, implementation and enforcement of a safety program. This program requires, among other things, the proper selection of point-of-operation guards and safety devices for each particular job or operation, a thorough safety training program for all machine personnel, that includes instruction on the proper operation of the machine, the point-of-operation guards and safety devices on the machine, and a regularly scheduled inspection and maintenance program.

Rules and procedures covering each aspect of your safety program should be developed and published both in an operator's safety manual, as well as in prominent places throughout the plant and on each machine. Some rules or instructions which must be conveyed to your personnel and incorporated into your program include:

 **DANGER** Never place your hands or any part of your body in this machine.

 **DANGER** Never operate this machine without proper eye, face and body protection.

 **Never** operate this machine unless you are fully trained, instructed, and have read the instruction manual.

 **Never** operate this machine if it is not working properly—stop operating and advise your supervisor immediately.

 **Never** use a foot switch to operate this machine unless a point-of-operation guard or device is provided and properly maintained.

 **Never** operate this machine unless two-hand trip, two-hand control or presence sensing device is installed at the proper safety distance. Consult your supervisor should you have any questions regarding the proper safety distance.

 **Never** tamper with, rewire or bypass any control or component on this machine.

A company's safety program must involve everyone in the company, from top management to operators, since only as a group can any operational problems be identified and resolved. It is everyone's responsibility to implement and communicate the information and material contained in catalogs and instruction manuals to all persons involved in machine operation. If a language barrier or insufficient education would prevent a person from reading and understanding various literature available, it should be translated, read or interpreted to the person, with assurance that it is understood.

 **For maintenance and inspection always refer to the OEM's (Original Equipment Manufacturer's) maintenance manual or owner's manual. If you do not have an owner's manual, please contact the original equipment manufacturer.**

Safety References

OSH ACT AND FEDERAL REGULATIONS

Since the enclosed equipment can never overcome a mechanical deficiency, defect or malfunction in the machine itself, OSHA (Occupational Safety and Health Administration) has established certain safety regulations that the employers (users) must comply with so that the machines used in their plants, factories or facilities are thoroughly inspected and are in first-class operating condition before any of the enclosed equipment is installed.

1. U.S. Government—An Act—Public Law 91-596, 91st Congress, S. 2193, December 29, 1970:

Duties

SEC. 5. (a) Each employer—

(1) shall furnish to each of his employees employment and a place of employment which are free from recognized hazards that are causing or are likely to cause death or serious physical harm to his employees;

(2) shall comply with occupational safety and health standards promulgated under this Act.

(b) Each employee shall comply with occupational safety and health standards and all rules, regulations, and orders issued pursuant to this Act which are applicable to his own actions and conduct.

2. OSHA 29 CFR Sections that an employer (user) must comply with include:

1910.211 Definitions.

1910.212 General requirements for all machines.

1910.217 Mechanical power presses.

1910.219 Mechanical power-transmission apparatus.

3. OSHA 29 CFR 1910.147 The control of hazardous energy (lockout/tagout).

4. OSHA Publication

“General Industry Safety and Health Regulations Part 1910,” Code of Federal Regulations, Subpart O

This publication can be obtained by contacting:

U.S. Government Printing Office
P.O. Box 371954
Pittsburgh, PA 15250-7954
Phone: (202) 512-1800
<http://bookstore.gpo.gov>

ANSI SAFETY STANDARDS FOR MACHINES

The most complete safety standards for machine tools are published in the ANSI (American National Standards Institute) B11 series. The following is a list of each ANSI B11 Standard available at the printing of this publication.

B11–2008	General Safety Requirements
B11.1	Mechanical Power Presses
B11.2	Hydraulic Power Presses
B11.3	Power Press Brakes
B11.4	Shears
B11.5	Iron Workers
B11.6	Lathes
B11.7	Cold Headers and Cold Formers
B11.8	Drilling, Milling, and Boring Machines
B11.9	Grinding Machines
B11.10	Metal Sawing Machines
B11.11	Gear and Spline Cutting Machines
B11.12	Roll Forming and Roll Bending Machines
B11.13	Automatic Screw/Bar and Chucking Machines
B11.14	Withdrawn (Now see ANSI B11.18)
B11.15	Pipe, Tube and Shape Bending Machines
B11.16	Metal Powder Compacting Presses
B11.17	Horizontal Hydraulic Extrusion Presses
B11.18	Coil Processing Systems
B11.19	Performance Criteria for Safeguarding
B11.20	Integrated Manufacturing Systems
B11.21	Lasers
B11.22	CNC Turning Machines
B11.23	Machining Centers
B11.24	Transfer Machines
B11.TR1	Ergonomic Guidelines
B11.TR2	Mist Control Considerations
B11.TR3	Risk Assessment
B11.TR4	Programmable Electronic Systems (PES/PLC)
B11.TR5	Sound Level Measurement Guidelines
B11.TR7	Risk Assessment
R15.06	Robotic Safeguarding
B15.1	Mechanical Power Transmission Apparatus
B56.5	Guided Industrial Vehicles and Automated Function of Manned Industrial Vehicles
B65.1	Printing Press Systems
B65.2	Binding and Finishing Systems
B65.5	Stand-Alone Pattern Presses
B151.1	Horizontal (Plastic) Injection Molding Machines
B152.1	Hydraulic Die Casting Presses
B154.1	Rivet Setting Machines
B155.1	Packaging Machinery
01.1	Woodworking Machinery

These standards can be purchased by contacting:

ANSI—American National Standards Institute
25 West 43rd Street, 4th Floor
New York, New York 10036
Phone: (212) 642-4900
www.ansi.org

(Continued on next page.)

SECTION 1—IN GENERAL

Arm-Type and Overhead-Type Restraints

NATIONAL SAFETY COUNCIL SAFETY MANUALS

Other good references for safety on machine tools are the National Safety Council's Safety Manuals. These manuals are written by various committees including the Power Press, Forging and Fabricating Executive Committee. Copies of the following publications are available from their library:

- Power Press Safety Manual - 5th Edition
- Safeguarding Concepts Illustrated - 7th Edition
- Forging Safety Manual

These manuals can be obtained by contacting:

National Safety Council
1121 Spring Lake Drive
Itasca, IL 60143-3201
1-800-621-7615
www.nsc.org

OTHER SAFETY SOURCES

National Institute of Occupational Safety and Health (NIOSH)
4676 Columbia Parkway
Cincinnati, OH 45226
Toll-Free: 1-800-35-NIOSH (1-800-356-4674)
Phone: (513) 533-8328
www.cdc.gov/niosh

OTHER SAFETY SOURCES (continued)

Robotic Industries Association (RIA)
900 Victors Way, Suite 140
P.O. Box 3724
Ann Arbor, MI 48106
Phone: (734) 994-6088
www.roboticonline.com

NEMA (National Electrical Manufacturers Association)
1300 North 17th Street, Suite 1847
Rosslyn, VA 22209
Phone: (703) 841-3200
www.nema.org

NFPA (National Fire Protection Association)
1 Batterymarch Park
Quincy, MA 02269-9101
Phone: (617) 770-3000
www.nfpa.org

For additional safety information and assistance in devising, implementing or revising your safety program, please contact the machine manufacturer, your state and local safety councils, insurance carriers, national trade associations and your state's occupational safety and health administration.

Warranty, Disclaimer and Limitation of Liability

WARRANTY

Rockford Systems, LLC warrants that this product will be free from defects in material and workmanship for a period of 12 months from the date of shipment thereof. ROCKFORD SYSTEMS LLC's OBLIGATION UNDER THIS WARRANTY IS EXPRESSLY AND EXCLUSIVELY LIMITED to repairing or replacing such products which are returned to it within the warranty period with shipping charges prepaid and which will be disclosed as defective upon examination by Rockford Systems, LLC. This warranty will not apply to any product which will have been subject to misuse, negligence, accident, restriction and use not in accordance with Rockford Systems, LLC's instructions or which will have been altered or repaired by persons other than the authorized agent or employees of Rockford Systems, LLC. Rockford Systems, LLC's warranties as to any component part is expressly limited to that of the manufacturer of the component part.

DISCLAIMER

The foregoing Warranty is made in lieu of all other warranties, expressed or implied, and of all other liabilities and obligations on the part of Rockford Systems, LLC, including any liability for negligence, strict liability, or otherwise, and any implied warranty of merchantability or fitness for a particular purpose is expressly disclaimed.

LIMITATION OF LIABILITY

Under no circumstances, including any claim of negligence, strict liability, or otherwise, shall Rockford Systems, LLC be liable for any incidental or consequential damages, or any loss or damage resulting from a defect in the product of Rockford Systems, LLC

Operator Safety Precaution Pamphlet - (Attachment for machine operators)



Front

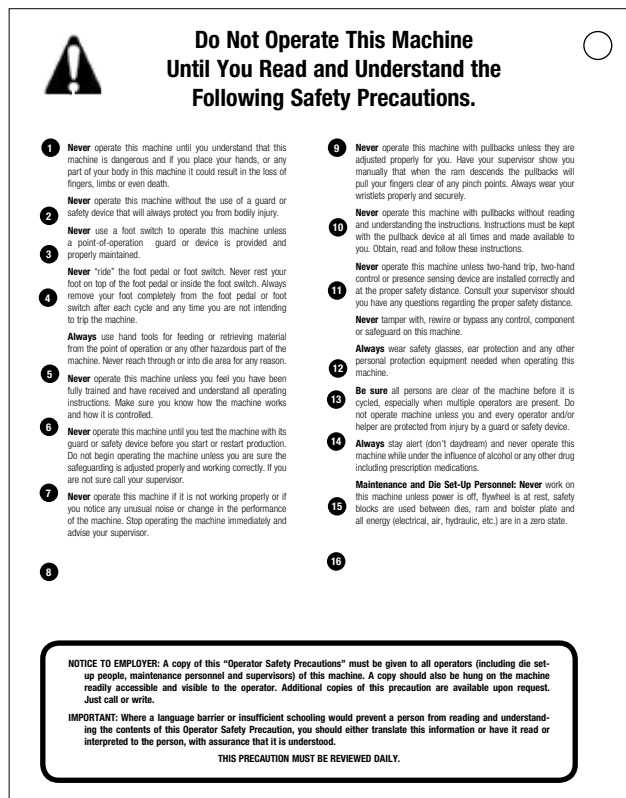

Back



Accompanying this equipment is an 8-1/2" x 11" operator safety precaution pamphlet, Part No. KSC-000, for anyone operating the machine where this equipment will be installed. This precaution pamphlet is to be given to all operators, including setup people, maintenance personnel and supervisors.



This pamphlet should also be attached to the machine, readily accessible and visible to the operator. (A hole in the corner of this precaution pamphlet is provided for attaching purposes.) Additional copies of this precaution are available. Please call, e-mail, write, fax, or use the order form found on a later page in this manual.



When a language barrier or insufficient education prevents a person from reading or understanding the contents of this operator safety precaution pamphlet, you should either translate this information or have it read or interpreted to the person. Make sure that the person understands the information. To order this pamphlet in Spanish, use Part No. KSC-000S; in French, use Part No. KSC-000F.



This precaution pamphlet must be reviewed daily.

SECTION 1—IN GENERAL

Arm-Type and Overhead-Type Restraints

Danger Sign(s) to be Mounted on Machine



Accompanying this equipment is a 5" x 6" polyethylene danger signs, Part No. KSC-054. These signs **MUST BE PERMANENTLY MOUNTED IN A PROMINENT LOCATION** on the machine where this equipment is installed. This sign must be in a **LOCATION THAT IS EASILY VISIBLE** to the operator, setup person, or other personnel who work on or around this machine. **ALWAYS** mount these signs with bolts or rivets when installing the enclosed equipment.

If any danger sign becomes destroyed or unreadable, the sign must be replaced immediately. Contact factory for replacement danger sign.



Never operate this machine unless the danger sign is in place.

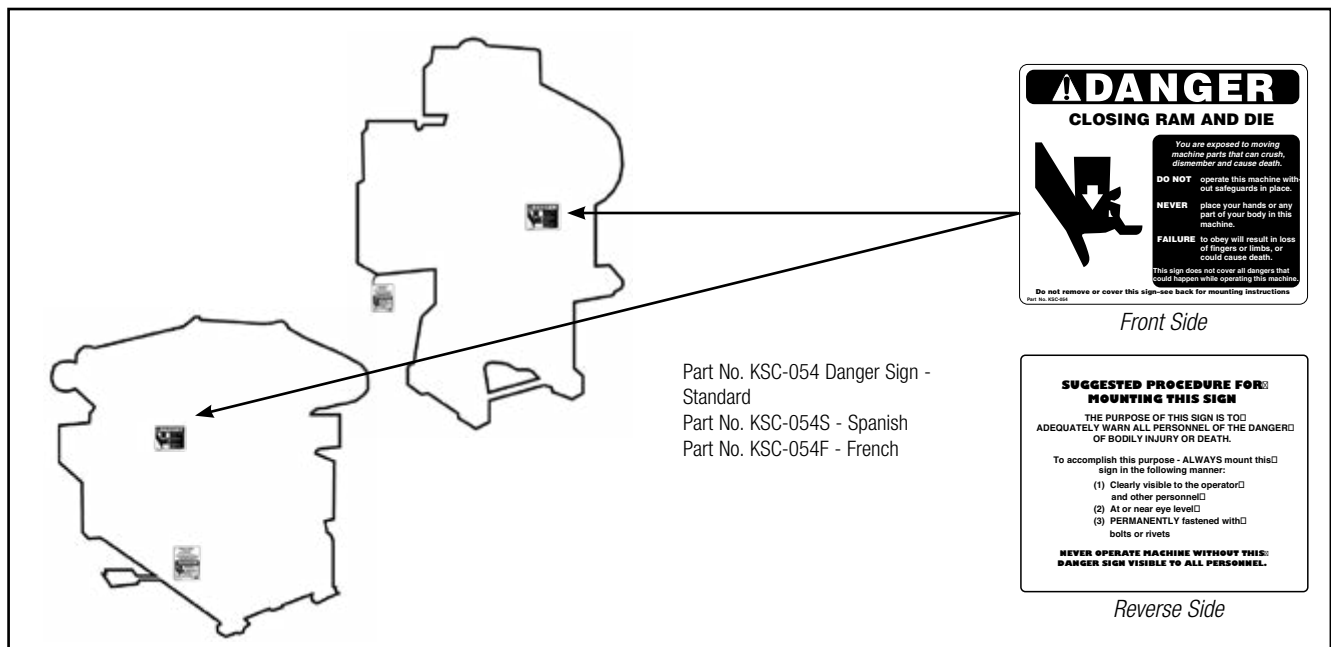

Mechanical Power Press Safety Booklet

A copy of the MPPS (*Mechanical Power Press Safety*) booklet (Part No. KSL-051) is available upon request. This booklet is copied verbatim from the CFR (Code of Federal Regulations) and contains all relevant sections of the OSHA standards concerning power presses with which an employer (user) must comply. The enclosed equipment must be installed, used and maintained to meet these standards. Specifically, any time a foot switch is used, a suitable **point-of-operation safeguard or device must be used** to prevent bodily injury. In addition, **every press must be provided with a point-of-operation safeguard!** Please review this booklet and the appropriate ANSI (American National Standards Institute) safety standards before installing the enclosed equipment. If you are unfamiliar with these detailed safety standards, which include regulations on safeguarding the point of operation properly, you may want to attend our regularly scheduled machine safeguarding seminars. To obtain detailed information about these training seminars, please call, fax, write, or check our Web site. Our address, telephone, fax number, and Web site address are on the front cover of this manual.

SECTION 2—RESTRAINT DEVICE MEASUREMENT DATA

Arm-Type and Overhead-Type Restraints

From _____

Ship to _____

Mach. No. _____ Mfg. _____ Model No. _____

If more than one machine is to be measured, please make copies of this page.

ARM RESTRAINT DEVICES

Side Mount (Std.)

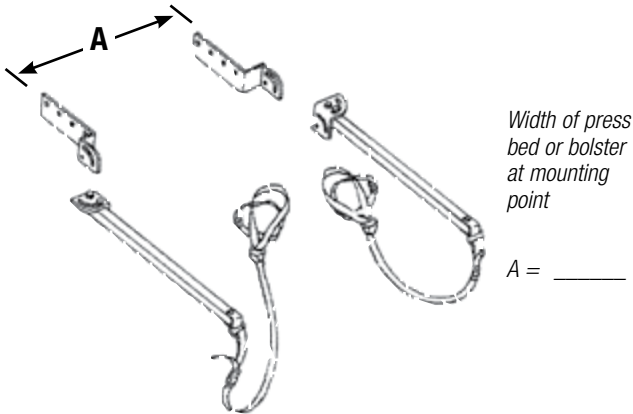

Front Mount

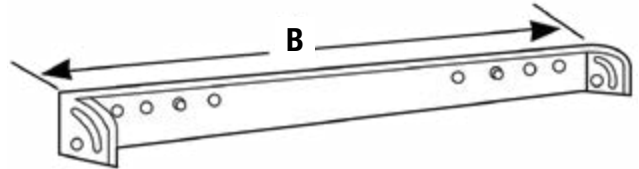

B =

25"	28"	32"

(Please Check One)

Split Front Mount

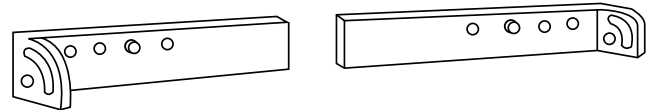

OVERHEAD RESTRAINT DEVICE

Single - Stationary

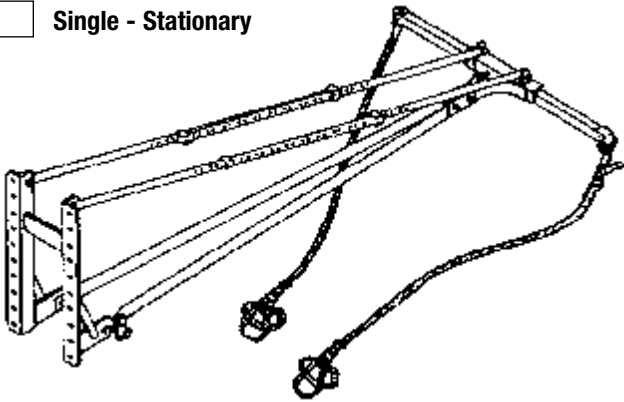

Sliding - Length of Rail (Max. 20')

One Person

Two Person

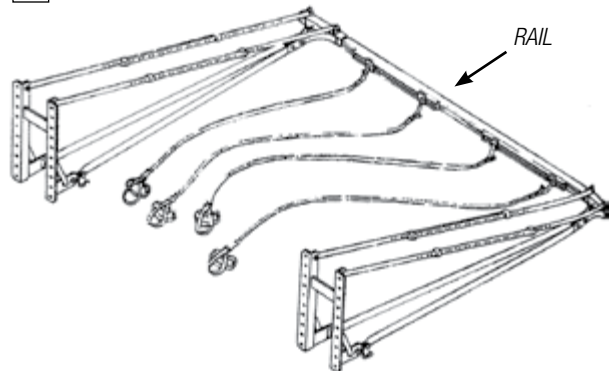

Note: An additional boom is provided when the rail is over 10' long.

For Manufacturer's Use Only

No. Units _____ Type _____

Mounts Arm _____

Straps _____

Wristlets _____

Brackets _____

S.O. Date _____

By: _____

Additional brackets may be selected from Overhead Pullback Measurement sheet, when necessary.



5795 Logistics Parkway
 Rockford, IL 61109
 Phone 1-800-922-7533
 Fax 815-874-6144

SECTION 3—INSTALLATION OF ARM-TYPE RESTRAINTS

Arm-Type and Overhead-Type Restraints

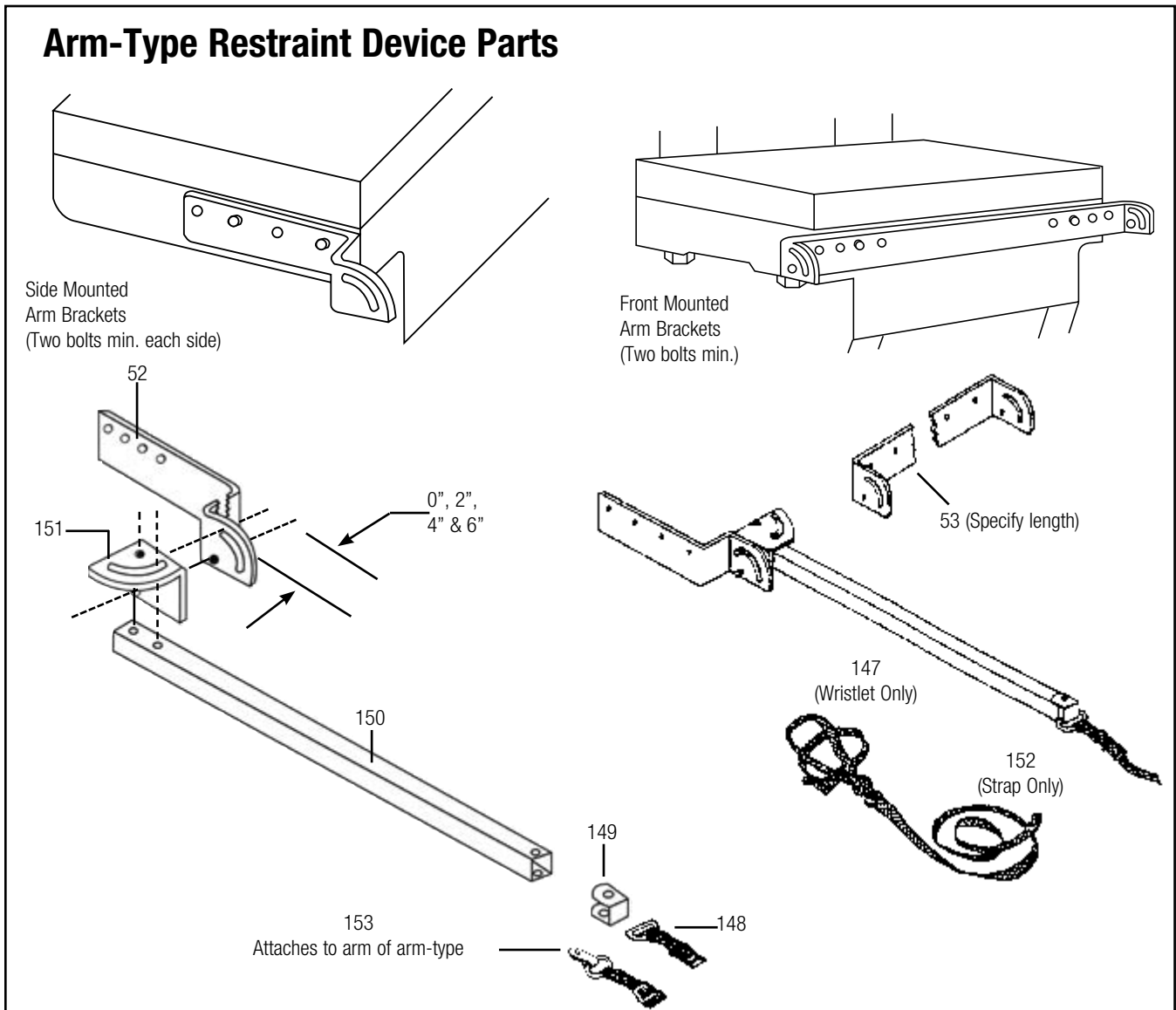

(Face Press to Determine Right or Left Side)

Item No.	Part No.	Description	Item No.	Part No.	Description
52	KYM-504	6" Arm Bracket - Right Side	147	WEB-200MN	Nylon Wristlets (Pair) Extra-Small
	KYM-505	6" Arm Bracket - Left Side		WEB-200S	Nylon Wristlets (Pair) Small
	KYM-506	4" Arm Bracket - Right Side		WEB-200M	Nylon Wristlets (Pair) Medium/Standard
	KYM-507	4" Arm Bracket - Left Side		WEB-200L	Nylon Wristlets (Pair) Large
	KYM-508	2" Arm Bracket - Right Side		WEB-200XL	Nylon Wristlets (Pair) Extra-Large
	KYM-509	2" Arm Bracket - Left Side	148	WEB-302	Restraint Device Connector- 1" D-Ring
	KYM-510	0" Arm Bracket - Right Side	149	KYM-438	Restraint Clip
	KYM-511	0" Arm Bracket - Left Side	150	KYM-436	Restraint Arm
53	KYM-512	25" Front Mounted Arm Bracket	151	KYM-437R	Arm Attachment - Right Side
	KYM-425	28" Front Mounted Arm Bracket		KYM-437L	Arm Attachment - Left Side
	KYM-513	32" Front Mounted Arm Bracket	152	WEB-301	Restraint Strap - 42" Long
			153	KYM-482	Arm-Type Restraint Connector

SECTION 3—INSTALLATION OF ARM-TYPE RESTRAINTS

Arm-Type and Overhead-Type Restraints

The arm-type restraint device is suitable for small and medium size presses when the operator is able to load and unload or hold parts without reaching into, along side of, or near the point of operation. They are commonly used for hand feeding of strip material or in conjunction with hand feeding tools.

Steps to Follow Before Installing Restraint

1. Unpack restraint, remove all shipping materials and lay out restraint device on work bench or floor.
2. The device consists of a mounting bracket, a tubular arm and an adjustable nylon strap, with wristlet attached, for each hand. Each arm is applied perpendicular to the front of the bolster and can be swung up to 90° to the side depending on the job situation. When not in use, the arms can be swung downward, out of the way.

The arms (1" square steel tubing) are 24" long with 42" nylon straps provided. This allows ample freedom of hand movement when operating from a sitting or a standing position. The nylon straps are fully adjustable for each operation and for each operator.

3. Make a sketch below of your installation to plan the location of the enclosed equipment on the machine.
4. Attach the bed arm mounting bracket(s). Use $\frac{3}{8}$ " - 24" x $1\frac{1}{4}$ " long hex head bolts with lock washers.
5. Mount the arms on the arm brackets. The lower hole on the brackets is to be used as a pivot point. Tighten the screw until you are able to pivot the arm with a medium amount of pressure and lock in place with the nut. The upper screw will lock the arm securely in place when the arms are in the up position.
6. Slip restraint device connector (148) over restraint clip (149) and attach clip to arm (150).
7. Next, tie one end of strap to wristlet (147) and secure other end of restraint strap to connector.
8. See pages 14 and 15, for additional installation and use information.

Note: Steps 6 and 7 may be factory assembled.

Layout Sketch

SECTION 4—INSTALLATION OF OVERHEAD-TYPE RESTRAINTS

Arm-Type and Overhead-Type Restraints

Single

The Overhead Restraint Device is suitable for large presses and press brakes. This device is a logical safeguarding choice when the operator never has to reach into, along side of, or near the point of operation to perform their job.

Through the use of an overhead frame, boom rails and braces, a support bar is situated above and behind the operator. Adjustable nylon straps, with wristlets, are attached to the support bar. This provides the operator with restraint protection for each hand but allows ample freedom away from the machine to handle large or clumsy parts without having to remove the wristlets.

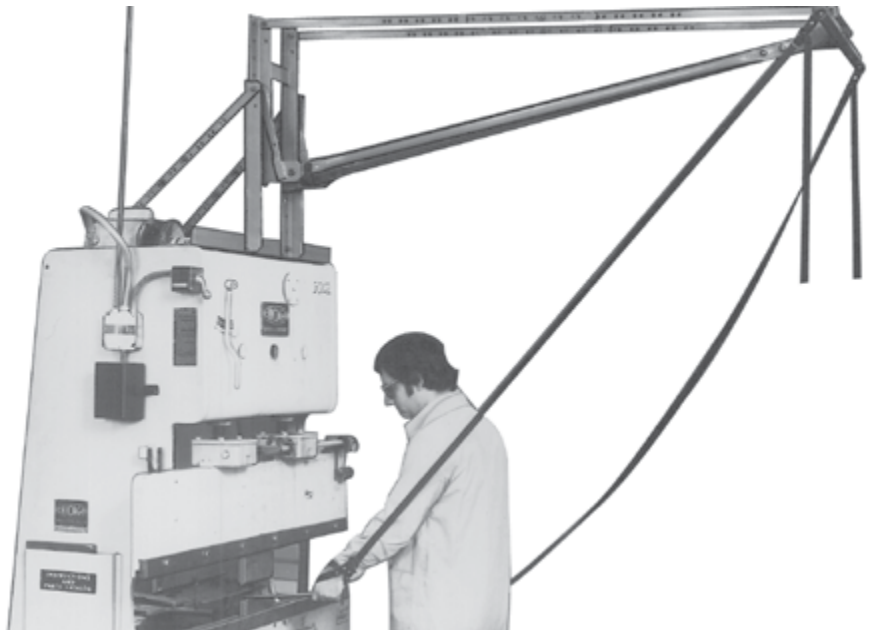

Sliding

On wide presses or press brakes, the operator may have to move laterally across the front of the machine or the job may require two or more operators on the same machine. When a restraint is installed for two operators, a length of “powerstrut” rail is hung above and behind the operator(s) through the use of two single restraint frames (see photo). A carrier travels along the “powerstrut” rail which provides lateral movement for each operator. A pair of restraint straps are attached to each of these carriers.

With this arrangement, each operator will be restricted to a certain reach toward the machine but will have lateral movement available through the sliding carriers. The straps must be adjusted so that the operator(s) is **never** allowed into the pinch point.

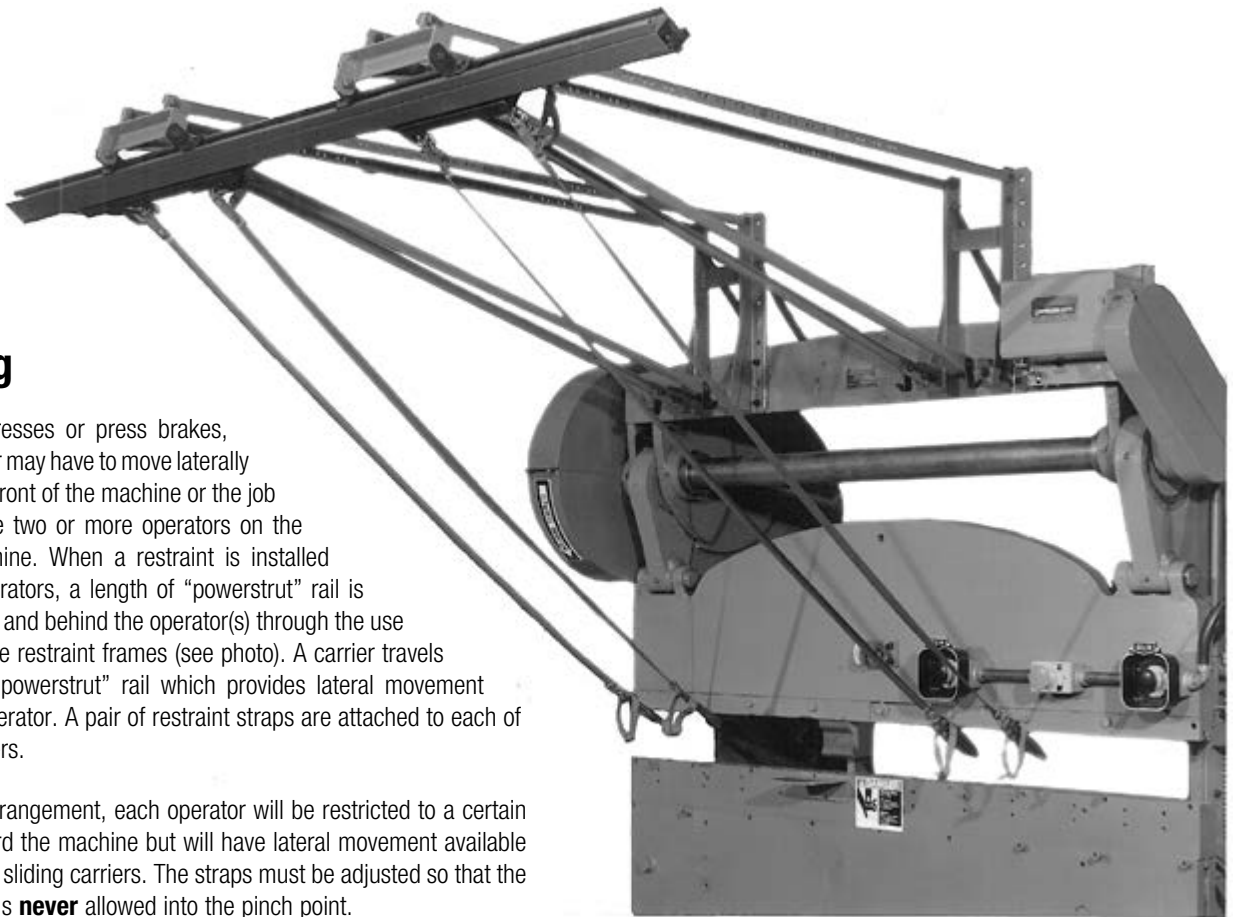

SECTION 4—INSTALLATION OF OVERHEAD-TYPE RESTRAINTS

Arm-Type and Overhead-Type Restraints

Overhead Restraint—Single

PARTS LAYOUT

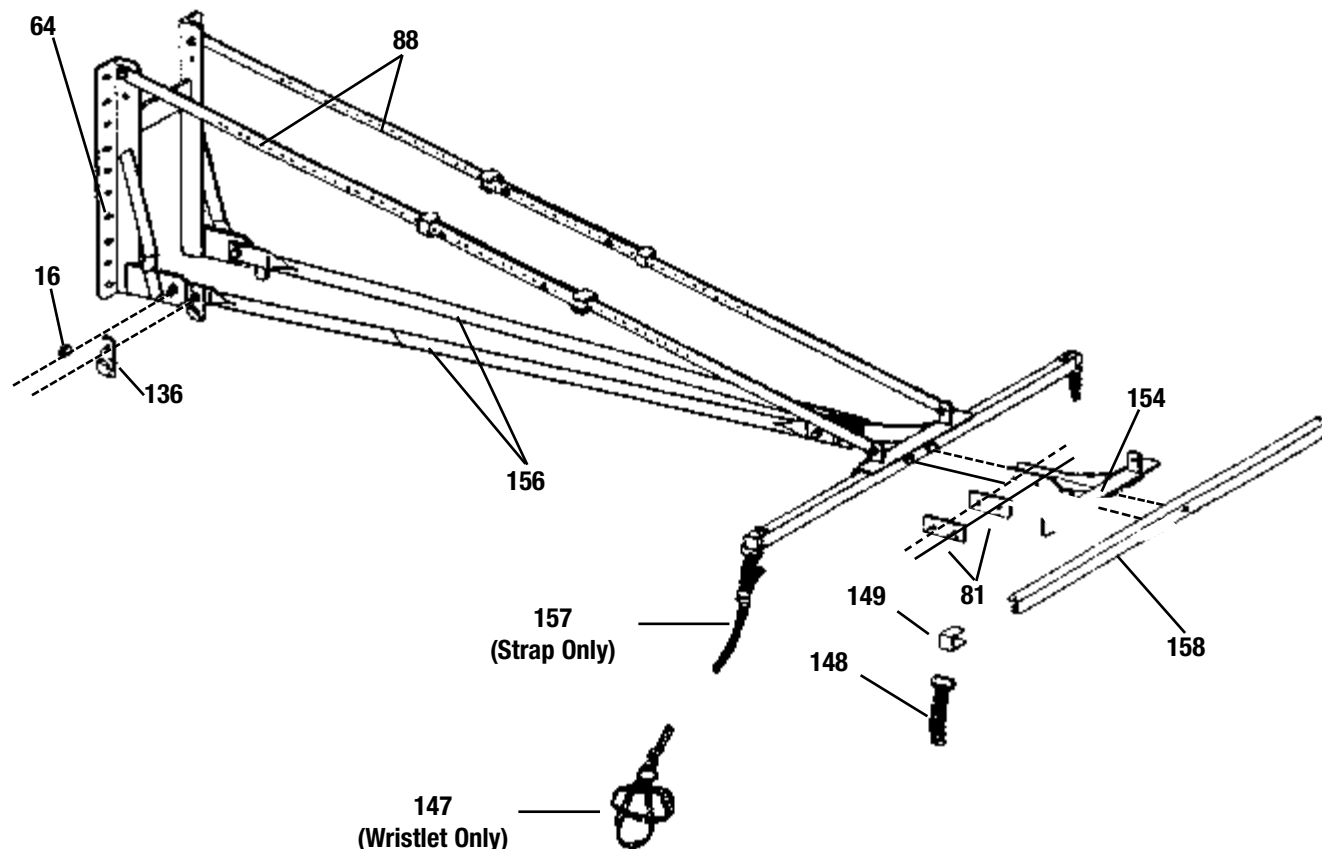

OVERHEAD-TYPE RESTRAINT PARTS

Item No.	Part No.	Description	Item No.	Part No.	Description
16	KYM-311	3/8" I.D. Porous Bronze Bushing	148	WEB-302	Restraint Device Connector - 1" D-Ring
64	KYM-484	Standard Mounting Frame	149	KYM-438	Restraint Clip
81	KYM-386	Boom Spacer Plate	154	KYM-514	Single Restraint Boom End
88	KYM-433	40 5/8" Long Boom Brace	156	KYM-434	58" Long Boom Rail
136	KYM-413	Wristlet Hanger	157	WEB-300	10' Long Restraint Strap
147	WEB-200MN	Nylon Wristlets (Pair) Extra-Small	158	KYM-476	Support Bar
	WEB-200S	Nylon Wristlets (Pair) Small			
	WEB-200M	Nylon Wristlets (Pair) Medium/Standard			
	WEB-200L	Nylon Wristlets (Pair) Large			
	WEB-200XL	Nylon Wristlets (Pair) Extra-Large			

SECTION 4—INSTALLATION OF OVERHEAD-TYPE RESTRAINTS

Arm-Type and Overhead-Type Restraints

Overhead Restraint—Sliding

PARTS LAYOUT

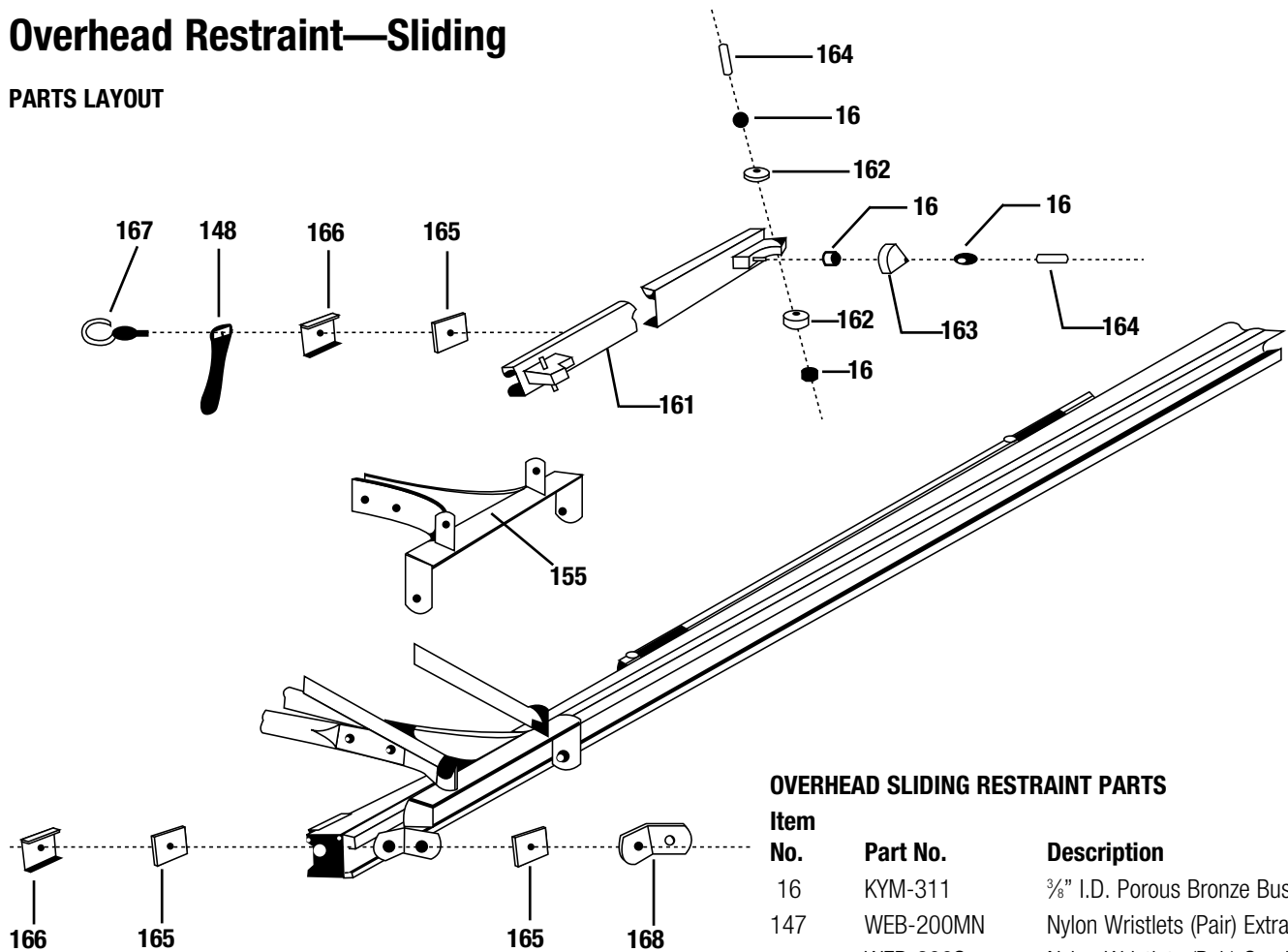

OVERHEAD SLIDING RESTRAINT PARTS

Item No.	Part No.	Description
16	KYM-311	3/8" I.D. Porous Bronze Bushing
147	WEB-200MN	Nylon Wristlets (Pair) Extra-Small
	WEB-200S	Nylon Wristlets (Pair) Small
	WEB-200M	Nylon Wristlets (Pair) Medium/Standard
	WEB-200L	Nylon Wristlets (Pair) Large
	WEB-200XL	Nylon Wristlets (Pair) Extra-Large
148	WEB-302	Restraint Device Connector - 1" D-Ring
155	KYM-515	Sliding Restraint Boom End
157	WEB-300	10' Long Restraint Strap
160	KYM-435	Guide Rail - Up to 20' Long - Specify Length
161	KYM-516	24" Carrier
	KYM-517	12" Carrier
162	KYM-518	Side Roller
163	KYM-519	Back Roller
164	KYM-520	Roller Pin
165	KYM-521	Rail Nut
166	KYM-522	Carrier Plate
167	KYM-523	Eye Bolt
168	KYM-524	Rail Swivel

SINGLE OR MULTIPLE OPERATORS

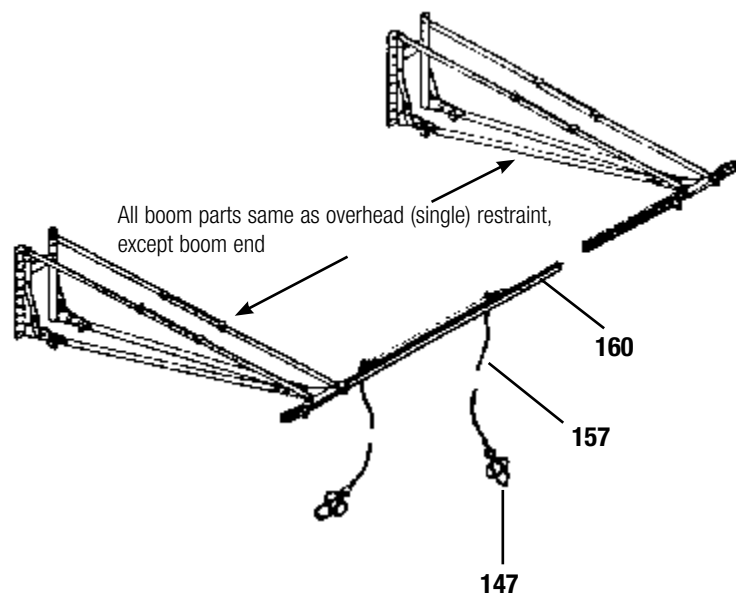

SECTION 4—INSTALLATION OF OVERHEAD-TYPE RESTRAINTS

Arm-Type and Overhead-Type Restraints

Installation Steps

1. Unpack restraint, remove all shipping materials and lay out restraint device on work bench or floor.
2. The device consists of a mounting frame, boom braces, boom rails, support bar, straps and wristlets. In some cases, special brackets may be furnished to attach the mounting frame. If desired, draw a layout sketch below.
3. Set up restraint as illustrated on pages 11 or 12 before mounting to the machine. On the single restraint, everything including the support bar can be assembled before attaching to the machine. On the sliding-type restraint, we suggest that the guide rail be installed after both booms have been mounted.
4. If special brackets are furnished for mounting frame(s), they are to be installed before restraint boom assembly is positioned up to the machine.
5. Additional personnel, fork lift, crane, etc., may be needed to position restraint assembly up to the machine. If special brackets have been installed or if holes have been drilled in the face of the machine, the restraint can then be securely mounted. If holes have not been drilled yet, spot hole locations by holding restraint up to the machine.
6. After boom(s), guide rail, etc., have been assembled on the machine, be sure to check that all fasteners are tight and secure.
7. At this time, the straps and wristlets should be attached. When adjusting strap length, make sure that the operator cannot reach into the point of operation at any time.

Layout Sketch

SECTION 5—PRELIMINARY CONSIDERATIONS FOR ALL RESTRAINTS

Arm-Type and Overhead-Type Restraints

Before adjusting and using the restraint systems, perform the following steps:

1. The components must be inspected, found in safe operating condition and the inspection recorded.
2. The operator must be wearing his wristlets and wearing them properly as illustrated below.

NYLON WRISTLETS

 **Always wear wristlets properly. These nylon wristlets have a hand loop, not a thumb loop. The four fingers—not the thumb—are inserted through the loop. The wrist strap buckle adjusts for comfort. The wristlet must be worn in this manner, as illustrated in the photo at right. To ensure the proper fit, wristlets are available in various sizes.**

 **Never wear wristlets with thumb through the loop.**

 **Never fail to fasten the wristband.**



3. Wristlets must be properly attached to the straps at all times.
4. There must be no bolts, studs, stops, blow-off tubes or other objects projecting in such a way that the wristlets, snaps or cables may be caught by them.
5. Do not allow the operator to wear rings or any other object which might become caught while operating the machine.

Adjusting Restraints or Hold-Outs

With the arms in the up position and the wristlets on the operator's hands, adjust (shorten) end attached to clip to restrain operator's extended finger tips from any possible nip point in the point of operation.

 **Always check finger clearance:**

1. After changing any adjustment,
2. After changing operators, dies, or shifts, and
3. As frequently as necessary to ensure that any restraint in use is properly adjusted for the job and for the operator using it.

Maintenance Requirements

1. All parts, fasteners and press mountings must be inspected frequently using a check list.
2. Straps must be examined daily and replaced if worn or damaged.
3. Inspect wristlets, wristlet rings, wristlet rivets and wristlet buckles daily. Replace all parts as soon as they show wear or damage.
4. Keep all mounting brackets, bolts and nuts secure and tight. Inspect daily.

 **Never operate this machine until you read and understand all instructions regarding the use of restraints.**

 **If this manual becomes lost, destroyed or unreadable, it must be replaced. Contact factory for replacement manual.**

SECTION 6—ORDER FORM FOR SIGNS AND LITERATURE

Arm-Type and Overhead-Type Restraints

This instruction manual references signs and literature available for your machines. This order form is for your convenience to order additional signs and/or literature as needed. (This order form is part of your installation manual so please make a copy of it when ordering.)

ORDER FORM FOR SIGNS AND LITERATURE

This instruction manual references signs and literature available for your machines. This order form is for your convenience to order additional signs and/or literature as needed. (This order form is part of your installation manual so please make a copy of it when ordering.)

Company _____

Address _____

City _____ State _____ Zip _____

Phone _____ Fax _____

Name _____ Purchase Order No. _____ Date _____

Part No.	Description	Quantity Required
KSL-191	Installation Manual	_____
KSC-054	Danger Sign 5" x 6" (English)	_____
KSC-054S	Danger Sign 5" x 6" (Spanish)	_____
KSC-054F	Danger Sign 5" x 6" (French)	_____
KSC-000	Operator Safety Precautions Sign (English)	_____
KSC-000S	Operator Safety Precautions Sign (Spanish)	_____
KSC-000F	Operator Safety Precautions Sign (French)	_____
KSL-051	Booklet—Mechanical Power Press Safety (MPPS)	_____
MSD	Catalog—Machine Safeguarding Devices	_____
SFM	Catalog—Shields For Machinery	_____

For prices and delivery, please use address, phone or fax number listed on the front cover of this manual.

Your Signature _____ Date _____

SECTION 7—RETURN MATERIALS REQUEST FORM

To return material for any reason contact the sales department in our organization at 1-800-922-7533 for an RMA Number. All returned materials shipments must be prepaid. Complete this form and send with material to 5795 Logistics Parkway, Rockford, IL 61109. Make sure the RMA Number is plainly identified on the outside of the shipping container.

Company _____

Address _____

City _____ State _____ Zip _____

Phone _____ Fax _____

Name _____ Representative _____

Items Authorized To Return on RMA No. _____ Original Invoice No. _____ Date _____

Part No.	Serial No.	Description
_____	_____	_____

Service Requested: Full Credit 25% Restocking Repair & Return Warranty Replacement

Reason for return (describe in detail): _____

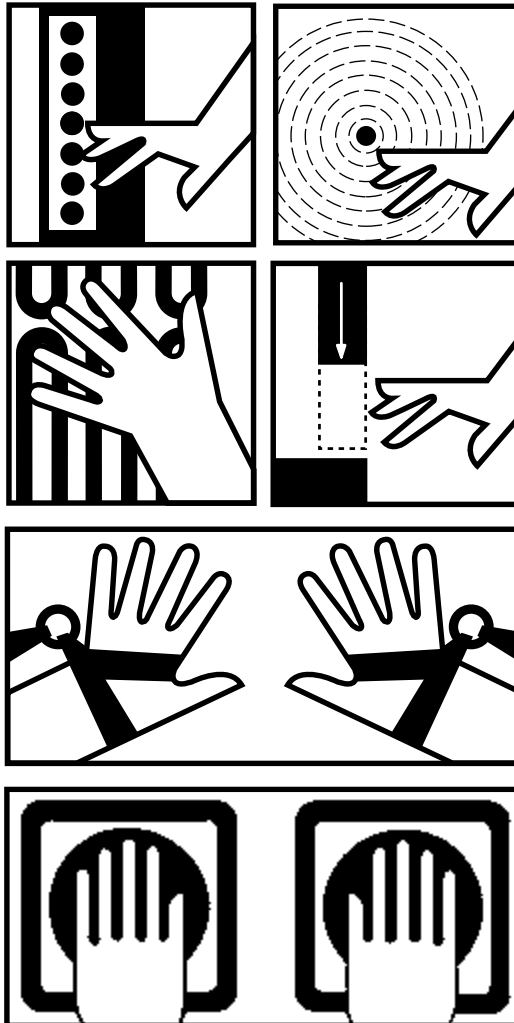

5795 Logistics Parkway

Rockford, Illinois 61109

Toll Free 1-800-922-7533

Phone 815-874-7891

Fax 815-874-6144

E-Mail sales@rockfordsystems.com

Web Site www.rockfordsystems.com