

INTRODUCTION

When safeguarding metal-fabricating machines other than mechanical power presses, the general requirements under OSHA are covered in the 29 CFR 1910.212. The basic concept is that any machine that creates a hazard must be safeguarded to protect the operator and other employees. OSHA can also cite violations under the General Duty Clause; Section 5(a) of OSHA states that: "Each employer (1) shall furnish to each of his employees: employment and a place of employment which are free from recognized hazards that are causing or are likely to cause death or serious physical harm to his employees; (2) shall comply with occupational safety and health standards promulgated under this Act. (b) Each employee shall comply with occupational safety and health standards and all rules, regulations, and orders issued pursuant to this Act which are applicable to his own actions and conduct."

OSHA 29 CFR 1910.212 also states that the safeguarding devices shall be in conformity with any appropriate standards . . . in the absence of applicable specific standards. The most complete safety standards for machine tools are published in ANSI B11 standards. The following is a list of each ANSI B11 standard available at the printing of this publication:

- B11.1 *Mechanical Power Presses*
- B11.2 *Hydraulic Power Presses*
- B11.3 *Power Press Brakes*
- B11.4 *Shears*
- B11.5 *Iron Workers*
- B11.6 *Manual Turning Machines (Lathes)*
- B11.7 *Cold Headers and Cold Formers*
- B11.8 *Drilling, Milling, and Boring Machines*
- B11.9 *Grinding Machines*
- B11.10 *Metal Sawing Machines*
- B11.11 *Gear and Spline Cutting Machines*
- B11.12 *Roll Forming and Roll Bending Machines*
- B11.13 *Automatic Screw/Bar and Chucking Machines*
- B11.14 *Coil Slitting Machines/Systems*
- B11.15 *Pipe, Tube, and Shape Bending Machines*
- B11.16 *Metal Powder Compacting Presses*
- B11.17 *Horizontal Hydraulic Extrusion Presses*
- B11.18 *Coil Processing Systems*
- B11.19 *Performance Criteria for Safeguarding*
- B11.20 *Manufacturing Systems/Cells*
- B11.21 *Lasers*
- B11.22 *Turning Centers and CNC Turning Machines*
- B11.23 *Machining Centers and CNC Milling, Drilling, and Boring Machines*
- B11.24 *Transfer Machines*
- B11.TR1 *Ergonomic Guidelines*
- B11.TR2 *Mist Control Considerations*
- B11.TR3 *Risk Assessment and Risk Reduction*
- B11.TR4 *Selection of Programmable Electronic Systems (PES/PLC)*

These standards can be purchased by contacting:

American National Standards Institute, Inc.,
25 West 43rd Street, 4th Floor
New York, NY 10036
(212) 642-4900

OR

AMT
The Association for Manufacturing Technology
7901 Westpark Drive
McLean, VA 22102
(703) 893-2900 • www.amtonline.org

Other good references for safety on machine tools are the National Safety Council's Safety Manuals. These manuals are written by various committees including the Power Press, Forging and Fabricating Executive Committee. Copies of the following publications are available from their library:

- *Power Press Safety Manual*, 5th Edition
- *Safeguarding Concept Illustrations*, 7th Edition
- *Forging Safety Manual*

These manuals can be obtained by contacting:

National Safety Council
1121 Spring Lake Drive
Itasca, IL 60143-3201
1-800-621-7619 • www.nsc.org

Other organizations also offer written information on machine safety. See page 236 for a list of other organizations.

Some states have their own OSHA machine safety regulations. If your state has a state-approved plan, a copy of these regulations should be acquired for reference when updating machines. Persons unfamiliar with interpretations of the performance language in OSHA and ANSI standards may want to attend one of our monthly machine safeguarding seminars detailed on pages 2 through 6 of this catalog.

The following pages explain how other metal-fabricating machines can be safeguarded. Because of their similarity to power presses and press brakes, many of the same types of safety equipment can be used when updating the machines discussed in this part of the catalog. The pages referenced throughout this section refer to previous catalog sections where safeguarding products are described.

IRON WORKER SAFEGUARDING

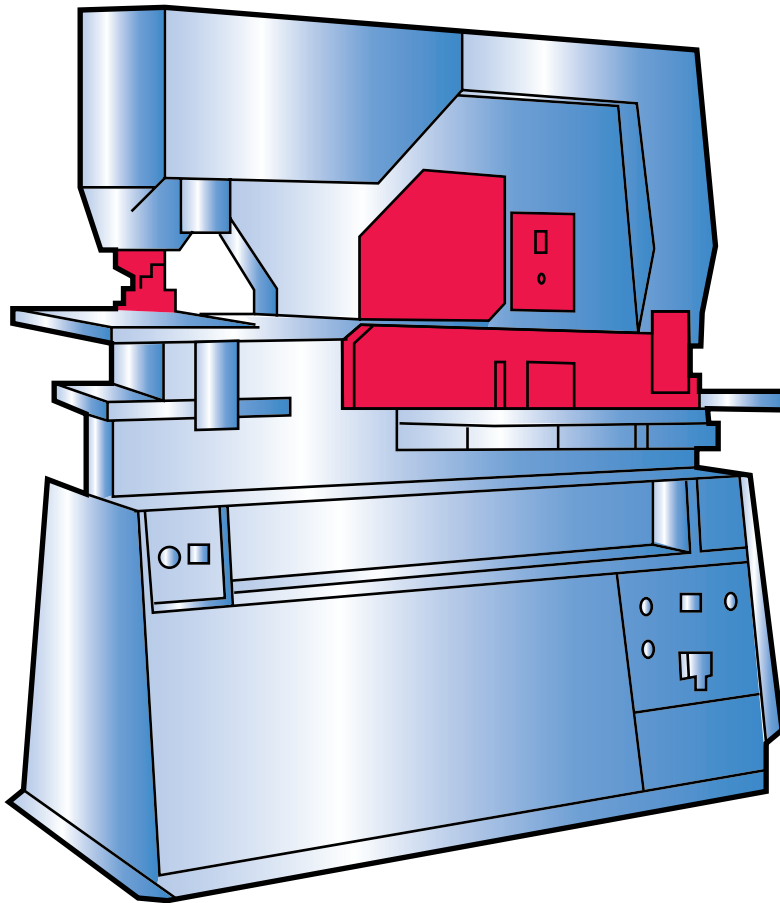

The detailed iron worker standard is ANSI B11.5. The same basic safeguarding principles described for shears on page 240 apply to these machines.

Most newer iron workers are equipped with color-coded guards at each area that creates a hazard. The guard is designed to protect the operator when these areas are not being used. New machines are equipped with an adjustable restrictor which surrounds the material ingoing areas. The restrictor should be adjustable to allow just enough clearance for the material to enter. Other safeguards, such as awareness barriers or presence-sensing devices, can also be considered.

Owners of older iron workers may want to go back

to the original equipment manufacturer for retrofit guards or fabricate their own using the safeguarding principles outlined in ANSI B11.5 as a guideline.

If the ironworker is equipped with a full-revolution clutch, it must have single-stroke capability. Single-stroke packages are explained on pages 90 through 100 of this catalog. Ironworkers require a main power disconnect switch, motor starter and covers over machine parts that create hazards.

Color-coding of hazard areas, warning signs and machine operator safety training can provide additional protection when safeguarding ironworkers.

SHEAR SAFEGUARDING

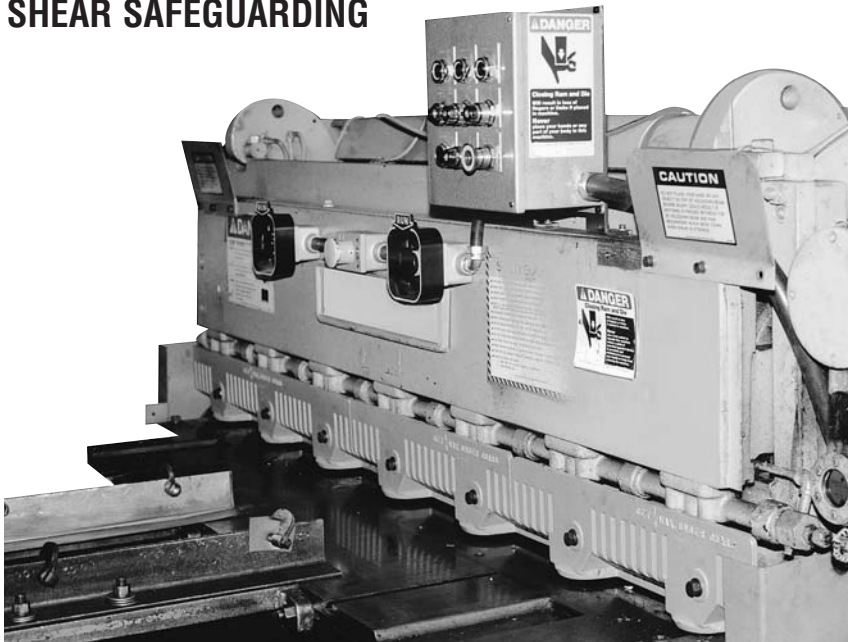

Squaring Shear Safeguarded With Guards and Two-Hand Control

There are many types of shears used in industry. The most common are squaring shears which are discussed on this page. Alligator, guillotine, and other types of shears are also common.

Most of the shears used in plants and fabricating shops are either mechanically or hydraulically powered. Manually operated shears are not discussed in these safety considerations.

As with power presses, we group safety in five basic areas. They are:

- 1) Safeguarding—How are the operators and other employees safeguarded from hazards?
- 2) Control—How is hazardous motion of the shear controlled?
- 3) Disconnect—Can electrical and pneumatic energy be disconnected and locked in the off position?
- 4) Starter—Does the motor starter automatically drop out when electrical power is lost so that it will not restart until the protected start button is pushed?
- 5) Cover—Are all mechanical power-transmission apparatuses covered up to 7 feet? (Hydraulic machines may not need covers.)

The two primary point-of-operation hazards on squaring shears are the shear blade and the material hold-downs. These hazards are usually safeguarded by the OEM's (original equipment manufacturer's) guard. If not, users can often go back to the OEM for this guard; or panels and mounts, as described on pages 11 through 44 of this catalog, can be furnished. Guards must meet

the opening requirements in the ANSI B11.4 shear safety standards. They must be adjusted so that operating personnel cannot get their hands or fingers into the hazard area. If the guard opening for feeding stacked or thicker material requires an opening that does not comply to the standard, an awareness barrier can often be used in its place (see ANSI B11.4 for details).

On shears equipped with a part-revolution clutch or for those which are hydraulically powered, light curtain presence-sensing devices can sometimes be used as described on pages 45 through 73. Shears using presence-sensing devices require control reliability. These same types of shears could also accept two-hand control as described on page 74. For hydraulic shears, please send electrical and hydraulic schematics for applying light curtains or two-hand control.

Other possible safeguards for shears are pull-backs, restraints, or gates. Please refer to the previous pages in this catalog for details.

If the C-frame throat is open on either side of the shear, this gap should be guarded. The back side should at least have a cable and push-button e-stop assembly as described on page 213.

On mechanical shears (using a flywheel for energy), either full-revolution or part-revolution clutches are used. These can be electrically, pneumatically or mechanically engaged. For full-revolution packages, see pages 90 through 100. For part-revolution packages, see pages 103 through 129. If an air cylinder is needed for a part-revolution package, see pages 172 or 173.

If a main power disconnect switch and magnetic motor starter are required, see pages 193 through 197. If the covers for the flywheel and gears are not already acceptable, they can be easily modified.

Additional safety considerations on shears can include hand tools, safety mats for the back side, color-coding of the hazard areas, warning signs, proper lighting, safety training, and personal protective safety equipment.

Another type of shear used in industry is an alligator shear. At the time of publication of this catalog, we are not aware of any positive safeguarding devices that could be used for operator protection on this type of machine. See roll benders for ideas on supplemental safety equipment which might be applied to alligator shears.

ROLL-FORMING MACHINES

Safety standards for roll-forming and roll-bending machines are detailed in ANSI B11.12 and fall under OSHA 29 CFR 1910.212. These machines are somewhat different in the way they roll material. For this reason, safeguarding may have to be applied differently than when it is applied to presses, etc.

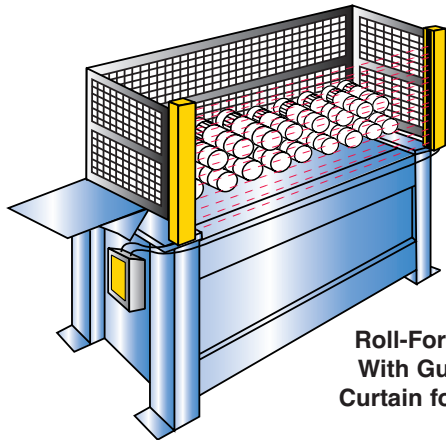

**Roll-Forming Machine
With Guard and Light
Curtain for Safeguarding**

Roll formers usually contain a series of numerous rolls which form material from coil stock. Sometimes power presses are inserted in the middle or end of the roll-forming line to punch holes or notches or to cut off the material as it moves through the process.

To safeguard the roll former and the presses, barrier guards can sometimes be used. Presence-sensing devices, such as light curtains or radio-frequency devices can also be applied. To provide access for on-the-fly adjustments or for other reasons, a combination of these safeguards may have to be used. Refer to pages 11 through 44 for guards and pages 45 through 73 for presence-sensing devices. Other auxiliary safety devices, such as safety mats found on pages 198-203, could possibly be used. Sometimes an emergency-stop device is used, see pages 190 and 212.

An electrical wiring schematic is required for proper interface of electrically interlocked guards or when tying in electrically operated devices. Other safety considerations on roll formers are a main power disconnect, motor starter, and covers for mechanical power-transmission apparatuses.

DEFINITIONS:

Awareness barrier: An awareness barrier is an attachment or method of safeguarding that offers resistance against entry or makes an employee aware of their entry into the point of operation, pinch point or hazard area.

Awareness device: An awareness device is a device that, by means of audible sound or visible light, warns an employee of an approaching or present hazard.

ROLL-BENDING MACHINES

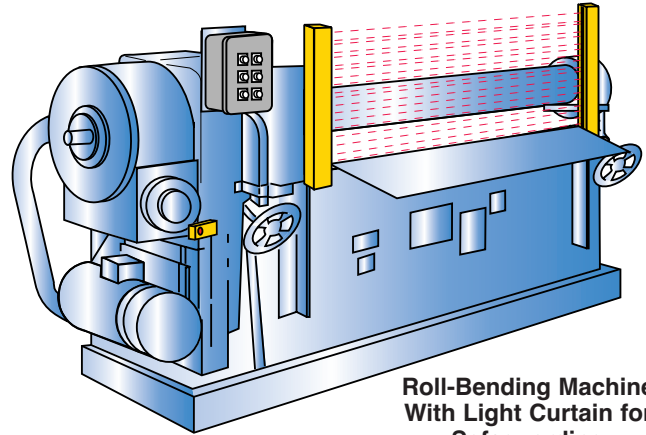

**Roll-Bending Machine
With Light Curtain for
Safeguarding**

Roll benders usually have three rolls arranged like a pyramid if viewed from their ends. A point-of-operation hazard is created between the ingoing rolls. Roll benders can be run by one or two operators. If the roll bender is dedicated to a limited size or configuration of workpieces, either a barrier guard or a light curtain is a possible safeguard. If the material does not need to be hand-supported by the operator, two-hand control can be used. General-purpose roll benders are used to bend a wide variety of sizes and types of materials. Because of this need for flexibility, the positive protection provided by a guard or device is often not possible.

In an attempt to protect their operators, some employers use a foot switch(es) to provide a “dead-man” or “hold-to-run” effect. If the operator(s) releases the foot switch(es), the rolls stop turning. If the roll bender does not have a clutch and brake, the rolls may coast before stopping. This hazardous motion presents another safety consideration.

Some roll benders are equipped with an emergency-stop device. On older machines, some employers choose to add an emergency-stop device. This can be in the form of a red push button, cable, bar, or kick plate tied into a switch and the machine control to provide a stop signal. This stop signal can be arranged to stop the motor drive, disengage the clutch and apply the brake and/or release rolls, if the machine is equipped with these features.

Awareness barriers, devices and signals are also a consideration. Some employers use additional safety equipment or practices such as safety mats, color-coding of hazard areas, warning signs, and training. They also ensure that their operators wear personal protective equipment. Loose clothing and jewelry should not be worn by personnel when operating a roll bender or any other machine.

As with other machines, roll benders require the proper disconnect switch, motor starter and covers for any mechanical power-transmission apparatus on the machine.

BENDING MACHINE SAFEGUARDING

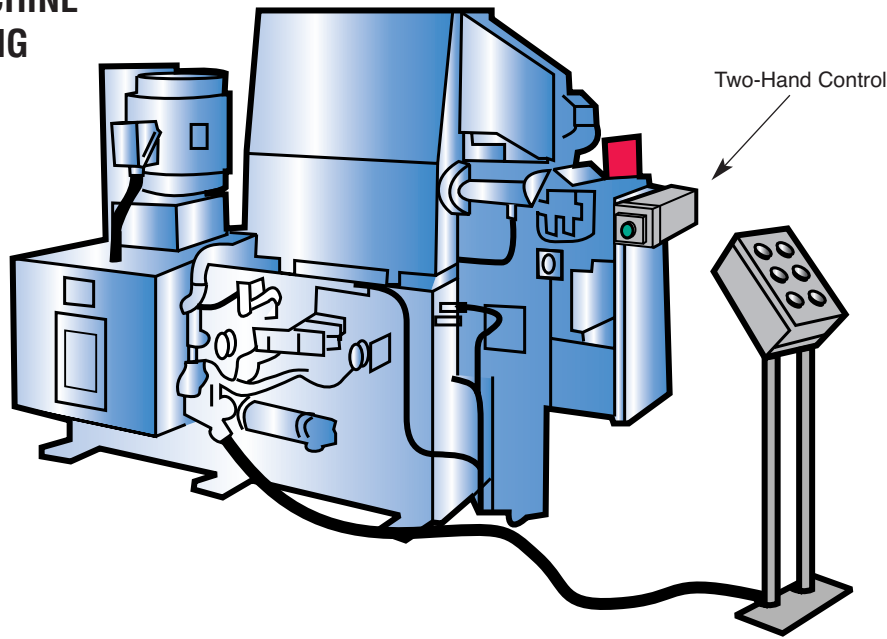

Vertical Bender With Two-Hand Control for Safeguarding

Safety for pipe-, tube-, and shape-bending machines is covered in ANSI B11.15 and OSHA 29 CFR 1910.212. There are many types of bending machines used in industry. The majority are either horizontal or vertical machines. A number of safeguards can be applied to both types of benders.

If a bender operates in an automatic mode, a barrier guard can be used to safeguard the point of operation. Two-hand control or a presence-sensing device can be used for safeguarding short-run operations that are manually fed.

Additional safeguarding can be accomplished using an awareness barrier, an emergency-stop device (cable, bar, or plate), warning signs and color-coding. Safety mats can sometimes be used to protect other employees, besides the operator, from point-of-operation hazards. As with any machine, proper training is also important.

The control system for hazardous machine motion should have control reliability designed into it. The proper disconnect switch and motor starter must be provided. Covers over mechanical power-transmission apparatuses are also required.

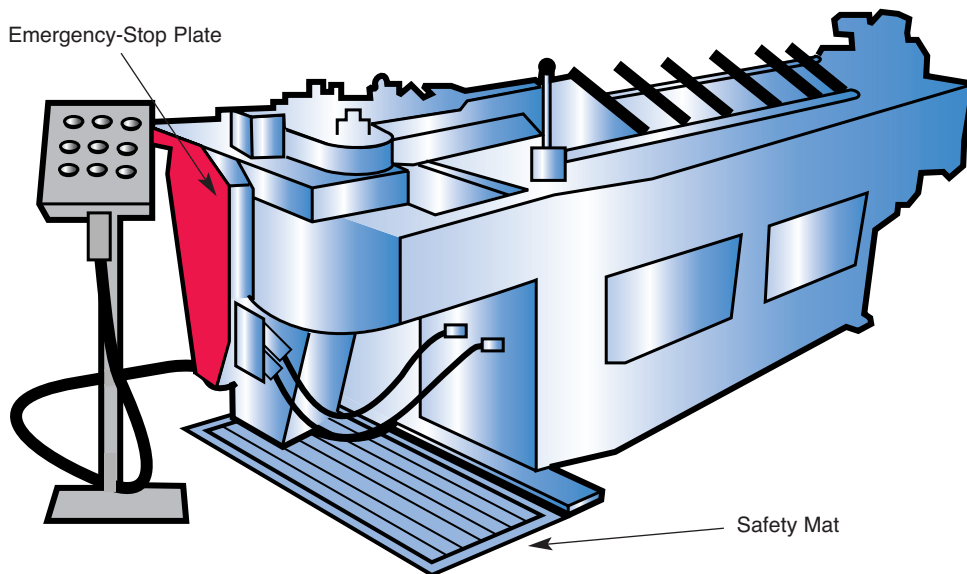

Horizontal Bender With Emergency-Stop Plate and Safety Mat for Safeguarding

SLIDE-FORMING MACHINE SAFEGUARDING

ANSI does not have a safety standard for slide-forming machines. As with other machines, they fall under OSHA 29 CFR 1910.212, General Machine Safeguarding for Protection of the Operator and Other Employees. The majority of slide-forming machines used in industry are multi-slide, four-slide, and vertical-slide machines.

Since these machines usually operate in the continuous or automatic mode, the two most commonly used point-of-operation safeguarding methods are barrier guards and presence-sensing devices (light curtains, single-beam devices or radio-frequency devices). When using presence-sensing devices, most employers use perimeter or work-envelope-type devices. This protects personnel from the numerous moving machine parts as well as from the hazards of the feed and pay-off reel. When applying interlocked guards or presence-sensing devices, be sure that a latch-out and reset feature is used to prevent someone from starting the machine while another person is working on it. See pages 12 through 73.

When an interlocked guard or a presence-sensing device is applied, the machine must have a reliable control system that will accept this safety equipment. Some slide formers may not have clutches or brakes. If this is the case, the machines may need to be retrofitted to make them capable of stopping hazardous motion before someone can reach into the point-of-operation hazard.

A proper disconnect switch and motor starter are required, and covers for mechanical power-transmission apparatuses are also needed.

AUTOMATIC PUNCHING MACHINE SAFEGUARDING

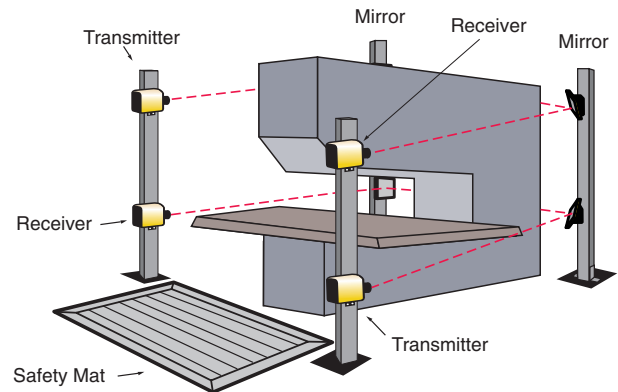

Perimeter Light Curtain or Single-Beam Devices With Mirrors and Safety Mats

OSHA 29 CFR 1910.212 requires employee protection for all machines that create hazards; therefore, punching machines must be safeguarded.

Due to machine design and construction, newer automatic punching machines may not create a hazard at the point of operation (where the punching takes place). The main safety concern is often the moving table. Employees can be protected by perimeter- or work-envelope-type safeguards such as guards, presence-sensing devices (light curtains or single beams), or safety mats. These safeguards are detailed on previous pages in this catalog.

On small manual punches, the punch stripper plate is usually designed to include a guard. If your machine is not equipped with this combination stripper/guard, you may want to contact the original equipment manufacturer.

As with most machines, punches must have the proper main power disconnect switch, motor starter, and covers.

FORGING MACHINE SAFEGUARDING

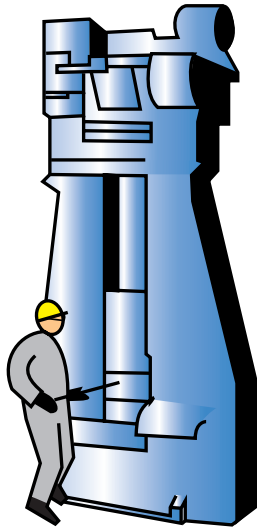

Forging Hammer

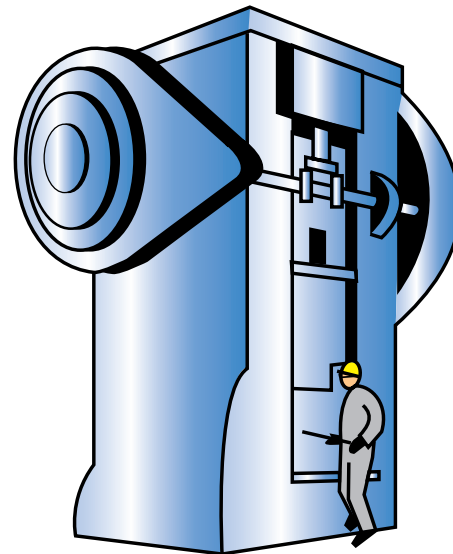

Forging Press

Safety for forging machines is detailed in OSHA 29 CFR 1910.218, ANSI B24.1, and in the National Safety Council's Forging Safety Manual.

Forging machines are categorized as drop hammers, steam hammers and as mechanical or hydraulic presses, etc. According to the standards and regulations, if an operator is manually feeding hot material, the main consideration for safeguarding the operator is to provide hand-feeding tongs. The tongs must be of sufficient length to clear the worker's body in case of kickback and cannot have sharp-ended handles that could cause injury. The standards and regulations also emphasize that operators must wear proper personal protective equipment during all forging operations.

For protection of operators and other employees in the machine area, scale (slag) guards should be installed on the backs of the machines. This is especially important for machines that are located behind one another. Scale guards are usually

fabricated of sheet metal and can be moved or swung out for die changing, maintenance, etc.

When someone must manually remove a stuck workpiece, a safety block must be used and the machine must be made inoperable. Blocks also must be used when changing dies and when other work is being done on the forging machine.

When forging machines are used for hot trimming, the previously discussed requirements apply. When cold forging or trimming, a point-of-operation safeguard must be used. Safeguard choices are guards, presence-sensing devices, two-hand control, pullbacks, restraints, and gate devices. When cold forging or trimming with a mechanical power press, OSHA 29 CFR 1910.217 and ANSI B11.1 should be used as a reference for compliance.

All forging and trimming hammers and presses must have the proper main power disconnect switch, motor starter, and covers for mechanical power-transmission apparatuses, when applicable.

COIL-SLITTING AND CUT-TO-LENGTH LINE SAFEGUARDING

Coil-slitting and cut-to-length lines are usually large rectangular shaped machines that slit or cut metal from coil stock. These machines run in an automatic mode; therefore, there is no need for the operator or other personnel to reach into the hazardous portion of the machine or auxiliary equipment. When running production, the perimeter or work envelope must be safeguarded. This is usually accomplished with guards, light

curtains, radio-frequency devices, single-beam devices, safety mats, etc. Other safety considerations could include awareness devices (barriers and visual or audible warnings), color-coding, warning signs, training, personal protective equipment, etc.

One of the most dangerous situations with this type of machinery is freeing a jam-up. The use of a latch-out and reset circuit and strict procedures should be practiced at all times on these machines.

ROBOT SAFEGUARDING

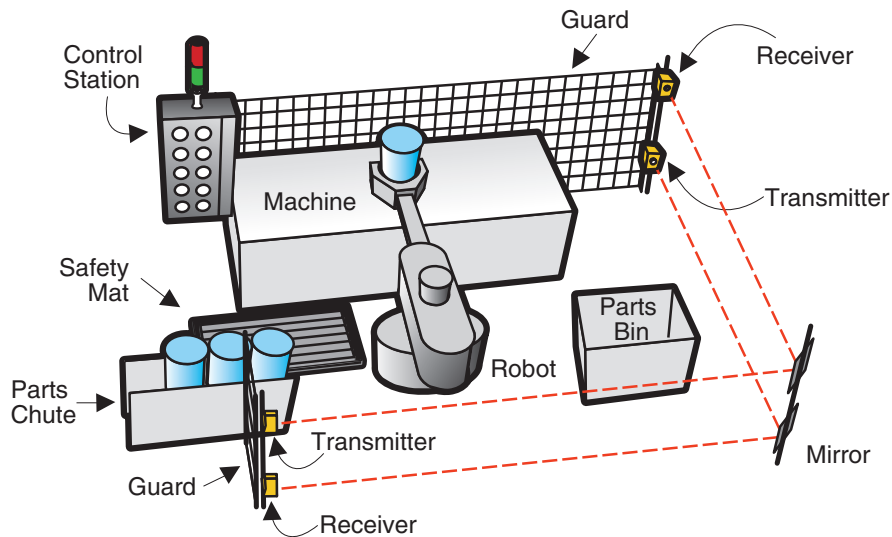

Example of Robot Auxiliary Equipment

A perimeter or work-envelope system is the most frequently used type of safeguarding around a robot or other machines and equipment. Safeguarding must also be considered on the equipment that the robot is feeding and/or retrieving as well as any other supportive or auxiliary equipment.

OSHA looks at robots like any other machines that create hazards to operating personnel—they must be safeguarded. Operators and others in the robot area must be protected from hazards created within the robot's work envelope. Hazards include entrapment, pinch points, ingoing nip points, chips, sparks, etc. Many of the hazards associated with robots are caused by movement of the robot's arm. Refer to ANSI/RIA R15.06, *Safety Standards for Industrial Robots and Robot Systems* for additional guidelines.

A light curtain or single-beam devices (presence-sensing devices) are probably the most versatile and positive means to safeguard the robot system. When an object enters the light, a stop signal is given, thus preventing injury and sometimes damage to the robot. With the use of mirrors, two, three, and even four sides of the perimeter area around the robot can be safeguarded.

When applying a perimeter light curtain, it should be at least 28" high and installed with the light curtain starting 16" from the floor. Light curtains can be applied on an angle or in the horizontal position when needed.

When applying single-beam devices, two beams per side must be applied. These lights should be mounted at 16" and 36" above the floor level. This prevents someone from going under or over them without being detected.

Another auxiliary safeguard is a pressure-sensitive safety mat. Mats can be used in two ways: individually or in groups. Individually, they are often used to protect a confined, specific area. When used in groups, they can be placed at the perimeter of the robot area. In either case, when someone steps on the mat, all hazardous motion must stop.

Another safeguarding method is barrier guards; like light curtains and mats, they can be used to safeguard the perimeter area around the robot. Guards are usually constructed to prevent operating personnel from reaching over, under, around, or through the guard into the hazard areas. If occasional access is needed through a door or other means, it must be interlocked with the robot control system. The interlock can be arranged with a shotpin so that the interlocked barrier section will not open until a preset time has elapsed, or until all motion has ceased. This allows the robot system to finish its sequence of operation after a stop signal has been given.

When safeguarding robotic systems, a combination of light devices, mats, and guards may have to be used to do an adequate job of protecting all personnel that may come into the area.

When applying the previously described safeguards, a rearm or reset arrangement must be used. This means that when a person(s) interrupts the light curtain, steps on the mat, or opens the door of an interlocked guard and enters the work envelope, that person(s) must reset the robot system once they have cleared the hazard area. The reset can be accomplished with a key-operated selector switch, push buttons, and a special program/procedure, etc. See pages 45 through 73 for light devices and latch-out devices.