

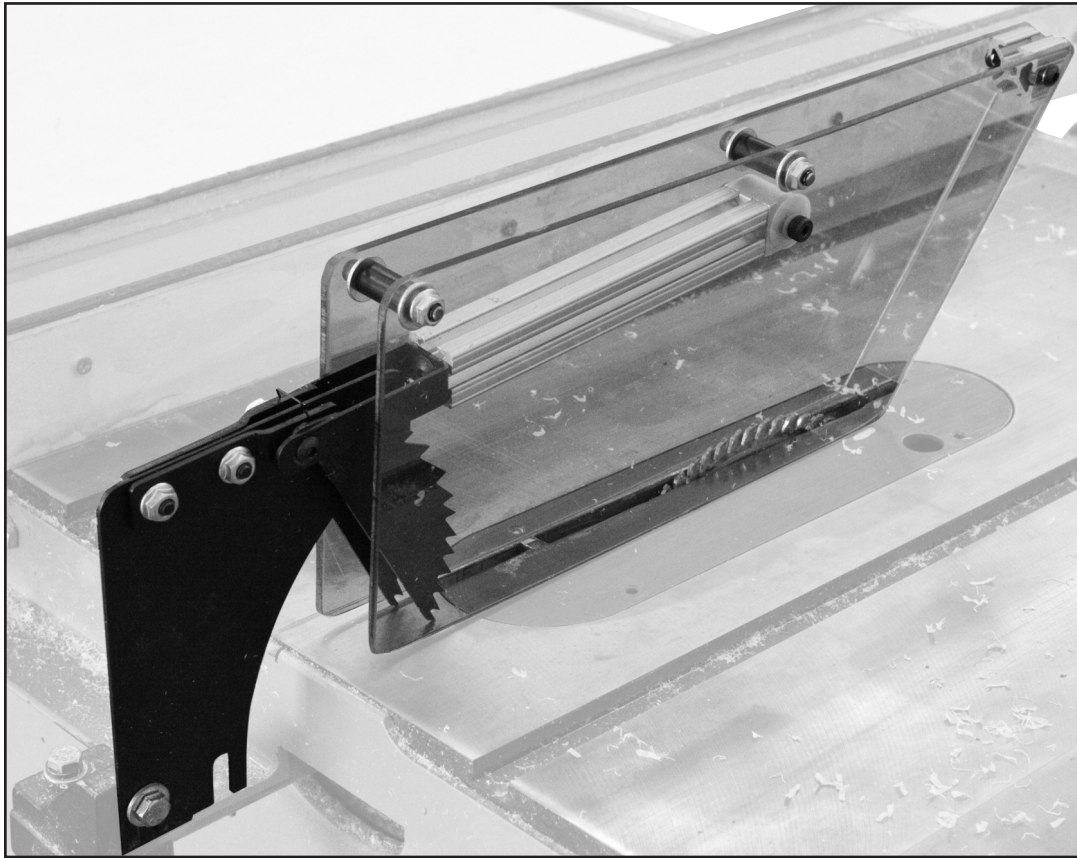

"The Machine Safeguarding People"

**ROCKFORD**  
SYSTEMS, INC.

# Table Saw Shield Assembly Instruction Manual



**⚠ DANGER** Never place your hands or any part of your body in this machine.



**Never** operate this machine without proper eye, face and body protection.



**Never** operate this machine unless you are fully trained and instructed and unless you have read the instruction manual.



**Never** operate this machine if it is not working properly—stop operating it and advise your supervisor immediately.

# MOUNTING AND ORDERING INFORMATION

## Table Saw Shield

### Introduction

This table saw shield is designed to enclose the portion of the saw above the table and enclose the portion of the saw above the material being cut. It is also designed so that the shield will automatically adjust itself to the thickness of and remain in contact with the material being cut—OSHA **1910.213 (c)(1)**.

The table saw shield assembly consists of a durable clear  $\frac{3}{16}$ "-thick polycarbonate, a spreader, and anti-kickback pawls—OSHA **1910.213 (c)(2)(3)**. An extruded aluminum arm and steel mounting brackets have slotted holes that provide adjustable mounting heights.

OSHA **1910.213 (a)(10)** also recommends that each power-driven woodworking machine be provided with a disconnect switch that can be locked in the off position.

### Installation

1. Remove all packing material from the shield and its mounting assembly. Remove any protective covering from the sides of the polycarbonate shield.
2. Drill and tap holes on the machine where the shield is to be located. Be careful when drilling holes into the frame of the machine. Avoid internal components that could affect machine operation.
3. Attach the mounting plate with fasteners (not furnished) to the machine. The anti-kickback pawls should be (at least) touching the work table. This will allow the pawls to adjust to the thickness of the material being cut.

**NOTE: The mounting plate is slotted for universal mounting and may need to be modified to fit your machine.**

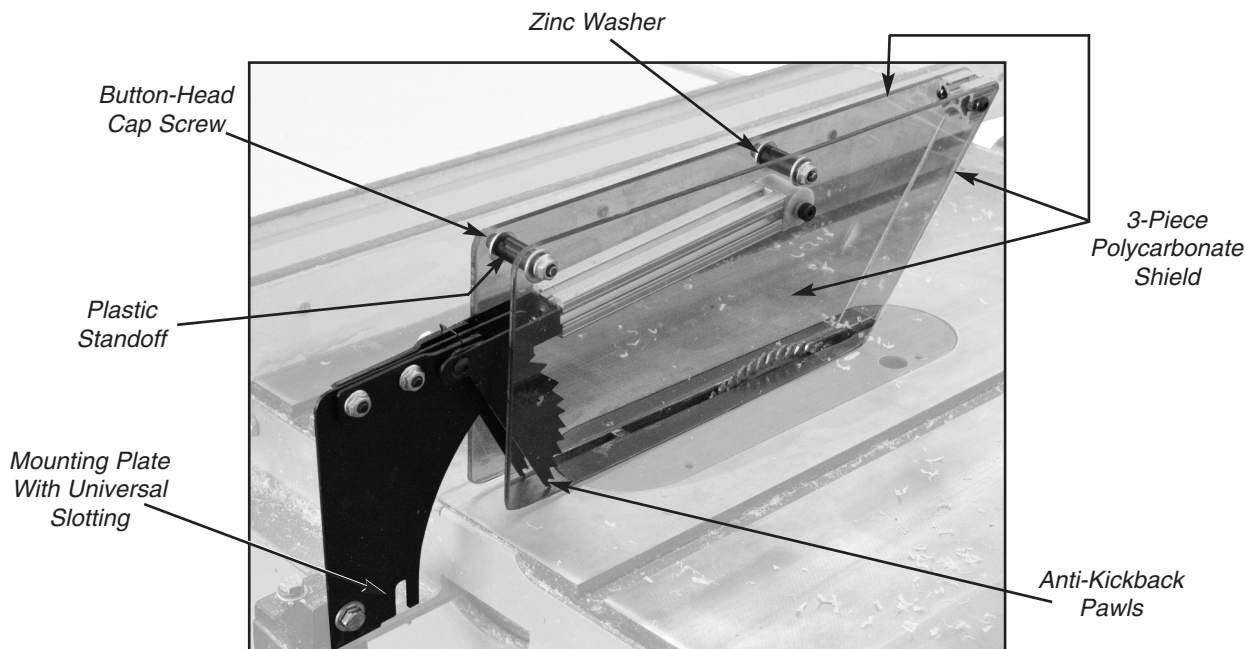

### ORDERING INFORMATION

Part No.	Description
KYL-319	Table Saw Shield Assembly—Complete
KYL-320	Table Saw Replacement Shield Only—3-Piece Polycarbonate
FSC-100	$\frac{1}{4}$ -20 x $1\frac{1}{4}$ " Socket-Head Cap Screw
FKT-1168	1" x $\frac{1}{2}$ " Plastic Standoff
FST-005	$\frac{1}{4}$ " Flat Zinc Washer