

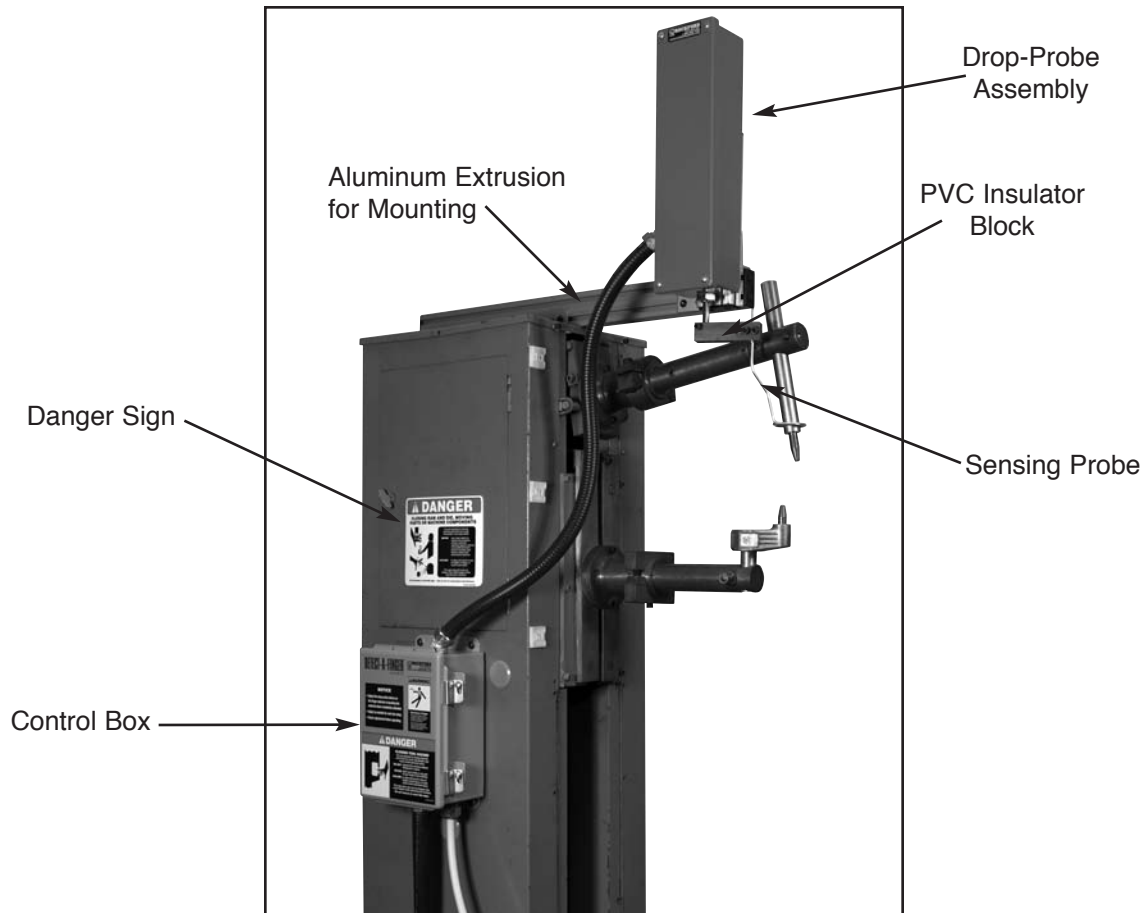

*"The Machine Safeguarding People"*

**ROCKFORD**  
SYSTEMS, INC.

# INSTALLATION MANUAL FOR ADJUSTABLE STROKE DETECT-A-FINGER® DROP-PROBE DEVICE



**IMPORTANT: PLEASE REVIEW THIS ENTIRE PUBLICATION BEFORE INSTALLING, OPERATING OR MAINTAINING THIS DEVICE.**

# SECTION 1—IN GENERAL

## Adjustable Stroke Detect-A-Finger® Drop-Probe Device

|  |        |                                       |       |
|--|--------|---------------------------------------|-------|
| SECTION 1 - IN GENERAL.....  | 2 - 8  | SECTION 3 - POWER-UP PROCEDURES ..... | 16    |
| SECTION 2 - INSTALLATION OF COMPONENTS .....                         | 9 - 15 | SECTION 4 - TROUBLESHOOTING .....     | 17-18 |
| Control Box .....  | 9      | SECTION 5 - REPLACEMENT PARTS .....   | 19    |
| Mini Filter-Regulator Assembly .....                                 | 10     | ORDER FORM .....                      | 20    |
| Drop-Probe Assembly, PVC Insulator Block,<br>and Sensing Probe ..... | 10-11  | RETURN AUTHORIZATION FORM.....        | 20    |
| Wiring and Air Tube Connection .....                                 | 12     |                                       |       |
| Other Components That May Be Required .....                          | 13-14  |                                       |       |
| Installation Considerations.....                                     | 15     |                                       |       |

## Safety Precautions

### DANGER

DANGER indicates an imminently hazardous situation which, if not avoided, will result in death or serious injury.



This safety alert symbol identifies important safety messages in this manual. When you see this symbol, be alert to the possibility of personal injury, and carefully read the message that follows.

### CAUTION

CAUTION used without the safety alert symbol indicates a potentially hazardous situation which, if not avoided, may result in property damage.

Efficient and safe machine operation depends on the development, implementation and enforcement of a safety program. This program requires, among other things, the proper selection of point-of-operation guards and safety devices for each particular job or operation, a thorough safety training program for all machine personnel, that includes instruction on the proper operation of the machine, the point-of-operation guards and safety devices on the machine, and a regularly scheduled inspection and maintenance program.

Rules and procedures covering each aspect of your safety program should be developed and published both in an operator's safety manual, as well as in prominent places throughout the plant and on each machine. Some rules or instructions which must be conveyed to your personnel and incorporated into your program include:

 **DANGER** Never place your hands or any part of your body in this machine.

 **DANGER** Never operate this machine without proper eye, face and body protection.

 **Never** operate this machine unless you are fully trained, instructed, and have read the instruction manual.

 **Never** operate this machine if it is not working properly – stop operating and advise your supervisor immediately.

 **Never** use a foot switch to operate this machine unless a point-of-operation guard or device is provided and properly maintained.

 **Never** operate this machine unless two-hand trip, two-hand control or presence sensing device is installed at the proper safety distance. Consult your supervisor should you have any questions regarding the proper safety distance.

 **Never** tamper with, rewire or bypass any control or component on this machine.

A company's safety program must involve everyone in the company, from top management to operators, since only as a group can any operational problems be identified and resolved. It is everyone's responsibility to implement and communicate the information and material contained in catalogs and instruction manuals to all persons involved in machine operation. If a language barrier or insufficient education would prevent a person from reading and understanding various literature available, it should be translated, read or interpreted to the person, with assurance that it is understood.

 **FOR MAINTENANCE AND INSPECTION ALWAYS REFER TO THE OEM's (ORIGINAL MACHINE MANUFACTURER'S) MAINTENANCE MANUAL OR OWNER'S MANUAL. If you do not have an owner's manual, please contact the original equipment manufacturer.**

## OSHA's Act and Federal Regulations

Since the enclosed equipment can never overcome a mechanical deficiency, defect or malfunction in the machine itself, OSHA (Occupational Safety and Health Administration) has established certain safety regulations that the employers (users) must comply with so that the machines used in their plants, factories or facilities are thoroughly inspected and are in first-class operating condition before any of the enclosed equipment is installed.

### 1. An Act – Public Law 91 - 596, 91st Congress, S. 2193, December 29, 1970

#### Duties:

Sec. 5. (a) Each employer —

- (1) shall furnish to each of his employees employment and a place of employment which are free from recognized hazards that are causing or are likely to cause death or serious physical harm to his employees;
- (2) shall comply with occupational safety and health standards promulgated under this Act.
- (b) Each employee shall comply with occupational safety and health standards and all rules, regulations, and orders issued pursuant to this Act which are applicable to his own actions and conduct.

### 2. OSHA's Code of Federal Regulations, Subpart O, that an employer (user) must comply with include:

Section 1910.211 Definitions  
Section 1910.212 (a) General Requirements for all Machines  
Section 1910.217 Mechanical Power Presses  
Section 1910.219 (b)(1) Mechanical Power-Transmission Apparatus (Flywheel and Gear Covers)

### 3. OSHA's 29 Code of Federal Regulations, Subpart J 1910.147 The Control of Hazardous Energy (Lockout / Tagout)

### 4. OSHA's Publications

- a. "General Industry Safety and Health Regulations Part 1910," Code of Federal Regulations, Subpart O
- b. "Concepts and Techniques of Machine Safeguarding," OSHA 3067, Revised 1992

These publications can be acquired by contacting:

US Department of Labor  
Occupational Safety and Health Administration  
Washington, DC 20210

### ANSI Safety Standards for Machines

The most complete safety standards for machine tools are published in the ANSI (American National Standards Institute) B11 series. The following is a list of ANSI B11 Standards available at the printing of this publication.

- B11.1 Mechanical Presses
- B11.2 Hydraulic Presses
- B11.3 Power Press Brakes
- B11.4 Shears
- B11.5 Ironworkers
- B11.6 Lathes
- B11.7 Cold Headers and Cold Formers
- B11.8 Drilling, Milling and Boring
- B11.9 Grinding Machines
- B11.10 Sawing Machines
- B11.11 Gear Cutting Machines
- B11.12 Roll Forming and Roll Bending
- B11.13 Automatic Screw/Bar and Chucking
- B11.14 Coil Slitting Machines
- B11.15 Pipe, Tube and Shape Bending
- B11.16 Metal Powder Compacting Presses
- B11.17 Horizontal Hydraulic Extrusion Presses
- B11.18 Coil Processing Systems
- B11.19 Performance Criteria for the Design, Construction, Care and Operation of Safeguards as Referenced in the Other B11 Machine Tool Safety Standards
- B11.20 Safety Requirements for Manufacturing Systems/Cells
- B11/TR1 Ergonomic Considerations for the Design, Installation and Use of Machine Tools
- R15.06 Robotic Safeguarding

These standards can be purchased by contacting:

American National Standards Institute, Inc.  
11 West 42nd Street  
New York, New York 10036  
(212) 642-4900

**OR**

AMT-The Association of Manufacturing Technology  
7901 Westpark Drive  
McLean, Virginia 22102-4269  
(703) 827-5211

(Continued on next page.)

# SECTION 1—IN GENERAL

## Adjustable Stroke Detect-A-Finger® Drop-Probe Device

### National Safety Council Safety Manuals and Data Sheets

Other good references for safety on machine tools are the National Safety Council's Safety Manuals and Data Sheets. These manuals and data sheets are written by various committees including the Power Press, Forging and Fabricating Executive Committee. The following publications are available for all types of machines:

#### MANUALS

Power Press Safety Manual - 4th Edition  
Safeguarding Concept Illustrations - 6th Edition  
Forging Safety Manual

#### DATA SHEETS

Bench and Pedestal Grinding Wheel Operations  
12304-0705  
Boring Mills, Horizontal Metal 12304-0269  
Boring Mills, Vertical 12304-0347  
Coated Abrasives 12304-0452  
Cold Shearing Billets and Bars in the Forging Industry  
12304-0739  
Degreasing (Liquid), Small Metal Parts 12304-0537  
Dies, Setup and Removal of Forging Hammer  
12304-0716  
Drill Presses, Metalworking 12304-0335  
Drills, Portable Reamer 12304-0497  
Drop Hammers, Steam 12304-0720  
Electrical Controls for Mechanical Power Presses  
12304-0624  
Forging Hammer Dies, Setup and Removal of  
12304-0716  
Forging Presses, Mechanical 12304-0728  
Gear-Hobbing Machines 12304-0362  
Handling Materials in the Forging Industry 12304-0551  
Kick (Foot) Presses 12304-0363  
Lathes, Engine 12304-0264  
Milling Machines, Metalworking 12304-0364  
Planers, Metal 12304-0383

Power Press (Mechanical) Point-of-Operation  
Safeguarding, Concepts of 12304-0710  
Power Press Point-of-Operation  
Safeguarding: Two-Hand Control and  
Two-Hand Tripping Devices 12304-0714  
Power Press Point-of-Operation Safeguarding: Type A  
and B Movable Barrier Devices 12304-0712  
Power Press Point-of-Operation Safeguarding:  
Point-of-Operation Guards 12304-0715  
Power Press Point-of-Operation Safeguarding:  
Presence Sensing Devices 12304-0711  
Power Press Point-of-Operation Safeguarding:  
Pullbacks and Restraint Devices 12304-0713  
Power Presses (Mechanical), Inspection and  
Maintenance of 12304-0603  
Power Presses (Mechanical), Removing Pieceparts  
from Dies in 12304-0534  
Power Press, Setting Up and Removing Dies  
12304-0211  
Press Brakes 12304-0419  
Robots 12304-0717  
Saws, Metal (Cold Working) 12304-0584  
Shapers, Metal 12304-0216  
Shears, Alligator 12304-0213  
Shears, Squaring, Metal 12304-0328  
Upsetters, 12304-0721

These manuals and data sheets can be purchased by contacting:

National Safety Council  
1121 Spring Lake Drive  
Itasca, IL 60143-3201  
1-800-621-7615 • www.nsc.org

For additional safety information and assistance in devising, implementing or revising your safety program, please contact the machine manufacturer, your state and local safety councils, insurance carriers, national trade associations and your state's occupational safety and health administration.

### Warranty, Disclaimer and Limitation of Liability

#### WARRANTY

Rockford Systems, Inc. warrants that this product will be free from defects in material and workmanship for a period of 12 months from the date of shipment thereof. ROCKFORD SYSTEMS INC.'S OBLIGATION UNDER THIS WARRANTY IS EXPRESSLY AND EXCLUSIVELY LIMITED to repairing or replacing such products which are returned to it within the warranty period with shipping charges prepaid and which will be disclosed as defective upon examination by Rockford Systems, Inc. This warranty will not apply to any product which will have been subject to misuse, negligence, accident, restriction and use not in accordance with Rockford Systems, Inc.'s instructions or which will have been altered or repaired by persons other than the authorized agent or employees of Rockford Systems, Inc. Rockford Systems, Inc.'s warranties as to any component part is expressly limited to that of the manufacturer of the component part.

#### DISCLAIMER

The foregoing Warranty is made in lieu of all other warranties, expressed or implied, and of all other liabilities and obligations on the part of Rockford Systems, Inc., including any liability for negligence, strict liability, or otherwise, and any implied warranty of merchantability or fitness for a particular purpose is expressly disclaimed.

#### LIMITATION OF LIABILITY

Under no circumstances, including any claim of negligence, strict liability, or otherwise, shall Rockford Systems, Inc. be liable for any incidental or consequential damages, or any loss or damage resulting from a defect in the product of Rockford Systems, Inc.

### Operator Safety Precautions Sign

○ **OPERATOR SAFETY PRECAUTIONS**

**Handout for Anyone Operating This Machine Before You Operate This Machine You Must Read and Understand These Safety Precautions**

DANGER



**NEVER**

Place Your Hands or Any Part of Your Body in This Machine

**See Reverse Side for Other Safety Precautions.**

SIGN NO. KSC-000

**OVER** 

*Front*



**Do Not Operate This Machine Until You Read and Understand the Following Safety Precautions.**

○

**1** Never operate this machine until you understand that this machine is dangerous and if you place your hands, or any part of your body in this machine it could result in the loss of fingers, limbs or even death.

**2** Never operate this machine without the use of a guard or safety device that will always protect you from bodily injury.

**3** Never use a foot switch to operate this machine unless a point-of-operation guard or device is provided and properly maintained.

**4** Never "ride" the foot pedal or foot switch. Never rest your foot on top of the foot pedal or inside the foot switch. Always remove your foot completely from the foot pedal or foot switch after each cycle and any time you are not intending to trip the machine.

**5** Always use hand tools for feeding or retrieving material from the point of operation or any other hazardous part of the machine. Never reach through or into die area for any reason.

**6** Never operate this machine unless you feel you have been fully trained and have received and understand all operating instructions. Make sure you know how the machine works and how it is controlled.

**7** Never operate this machine until you test the machine with its guard or safety device before you start or restart production. Do not begin operating the machine unless you are sure the safeguarding is adjusted properly and working correctly. If you are not sure call your supervisor.

**8** Never operate this machine if it is not working properly or if you notice any unusual noise or change in the performance of the machine. Stop operating the machine immediately and advise your supervisor.

**9** Never operate this machine with pullbacks unless they are adjusted properly for you. Have your supervisor show you manually that when the ram descends the pullbacks will pull your fingers clear of any pinch points. Always wear your wristlets properly and securely.

**10** Never operate this machine with pullbacks without reading and understanding the instructions. Instructions must be kept with the pullback device at all times and made available to you. Obtain, read and follow these instructions.

**11** Never operate this machine unless two-hand trip, two-hand control or presence sensing device are installed correctly and at the proper safety distance. Consult your supervisor should you have any questions regarding the proper safety distance.

**12** Never tamper with, rewire or bypass any control, component or safeguard on this machine.

**13** Always wear safety glasses, ear protection and any other personal protection equipment needed when operating this machine.

**14** Be sure all persons are clear of the machine before it is cycled, especially when multiple operators are present. Do not operate machine unless you and every operator and/or helper are protected from injury by a guard or safety device.

**15** Always stay alert (don't daydream) and never operate this machine while under the influence of alcohol or any other drug including prescription medications.

**16** Maintenance and Die Set-Up Personnel: Never work on this machine unless power is off, flywheel is at rest, safety blocks are used between dies, ram and bolster plate and all energy (electrical, air, hydraulic, etc.) are in a zero state.

**NOTICE TO EMPLOYER:** A copy of this "Operator Safety Precautions" must be given to all operators (including die set-up people, maintenance personnel and supervisors) of this machine. A copy should also be hung on the machine readily accessible and visible to the operator. Additional copies of this precaution are available upon request. Just call or write.

**IMPORTANT:** Where a language barrier or insufficient schooling would prevent a person from reading and understanding the contents of this Operator Safety Precaution, you should either translate this information or have it read or interpreted to the person, with assurance that it is understood.

THIS PRECAUTION MUST BE REVIEWED DAILY.

*Back*



Accompanying this equipment is an 8½" x 11" operator safety precautions sign, Part No. KSC-000, for anyone operating the machine where this equipment will be installed. This precautions sign is to be given to all operators, including setup people, maintenance personnel and supervisors.



This sign should also be attached to the machine, readily accessible and visible to the operator. (A hole in the corner of this precautions sign is provided for attaching purposes.) Additional copies of these precautions are available. Please call, write, fax, or use the order form found on a later page in this manual.



When a language barrier or insufficient education prevents a person from reading or understanding the contents of this operator safety precautions sign, you should either translate this information or have it read or interpreted to the person. Make sure that the person understands the information. To order this sign in Spanish, use Part No. KSC-000S; in French, use Part No. KSC-000F.



These precautions must be reviewed daily.

# SECTION 1—IN GENERAL

## Adjustable Stroke Detect-A-Finger® Drop-Probe Device

### Danger Sign(s) to be Mounted on Machine



Accompanying this equipment is a 5" x 6" polyethylene danger sign, Part No. KSC-055. This sign **MUST BE PERMANENTLY MOUNTED IN A PROMINENT LOCATION** on the machine where this equipment is installed. This sign must be in a **LOCATION THAT IS EASILY VISIBLE** to the operator, setup person, or other personnel who work on or around this machine. **ALWAYS** mount this sign with bolts or rivets when installing the enclosed equipment.

If any danger sign becomes destroyed or unreadable, the sign **must** be replaced immediately. Contact factory for replacement danger sign(s).



**Never operate this machine unless danger signs are in place.**

Part No. KSC-000 Operator Safety Precautions Sign

**FRONT SIDE**

**REVERSE SIDE**

**SUGGESTED PROCEDURE FOR MOUNTING THIS SIGN**

THE PURPOSE OF THIS SIGN IS TO ADEQUATELY WARN ALL PERSONNEL OF THE DANGER OF BODILY INJURY OR DEATH.

To accomplish this purpose - ALWAYS mount this sign in the following manner:

- (1) Clearly visible to the operator and other personnel
- (2) At or near eye level
- (3) PERMANENTLY fastened with bolts or rivets

**NEVER OPERATE MACHINE WITHOUT THIS DANGER SIGN VISIBLE TO ALL PERSONNEL.**

### “Mechanical Power Press Safety” Booklet

A copy of Booklet No. MPPS (*Mechanical Power Press Safety*) is available upon request. This booklet is copied verbatim from the CFR (Code of Federal Regulations) and contains all relevant sections of the OSHA standards concerning power presses with which an employer (user) must comply. The enclosed equipment must be installed, used and maintained to meet these standards. Specifically, any time a foot switch is used, a suitable **point-of-operation safeguard or device must be used** to prevent bodily injury. In addition, **every press must be provided with a point-of-operation safeguard!** Please review this booklet before installing the enclosed equipment. If you are unfamiliar with these detailed safety regulations, which include regulations on safeguarding the point of operation properly, you may want to attend our regularly scheduled machine safeguarding seminars. To obtain detailed information about these training seminars, please call, fax, write, or check our Web site. Our telephone, fax number, Web site, and mailing address are on the front cover of this manual.

**mechanical power press safety**

Any component of the safety system mounted on this press is available from one source...

**ROCKFORD SYSTEMS, INC.**

4401 Vermont Road  
Rockford, IL 61109-2055  
Tel: (815) 922-7533  
Fax: (815) 922-7534  
Phone: (815) 924-2921  
E-mail: sales@rockfordsystems.com  
Web Site: rockfordsystems.com

Safety requirements for power presses listed in OSHA's Code of Federal Regulations (Subpart O), 1910.217, 1910.212 and 1910.215.

Catalog MPPS  
Part No. 100-005  
PRICE \$3.00

## Components in the System

- Control box
- Drop-probe assembly
- Mini filter-regulator assembly
- Air tubing ( $\frac{5}{32}$ " x 25' PVC tubing)
- Sensing probe
- Aluminum extrusion for mounting
- Danger signs

### ADDITIONAL COMPONENTS THAT MAY BE REQUIRED

- Foot switch
- Air cylinder—for mechanical to electrical conversion
- Dual-solenoid or single-solenoid air valve assembly
- Air lockout valve

## Preliminary Steps Before Installation

Before proceeding with the installation of the enclosed equipment, you should undertake the following preliminary steps.

1. Read and make sure you understand this entire installation manual.
2. Refer to the front cover, other line drawings and photos, then make a sketch of your installation to plan the location of the enclosed equipment on the machine.
3. **Please make sure the machine is in first-class condition.** Before starting any installation, it is essential that the machine is thoroughly inspected. Be sure all mechanical components and all collateral equipment are in first-class operating condition. Your inspection should be done according to the machine manufacturer's installation and maintenance instruction manual. If you have any doubts or questions concerning the condition of the machine, contact the machine manufacturer for assistance. **Repair or replace all parts not operating properly before proceeding.**



**Inspection and maintenance programs must be established and implemented to keep machines in first-class condition. Safety programs must include thorough inspections of each machine on a weekly basis and records kept of these inspections. Any part of the machine that is worn, damaged or is not operating properly must be replaced immediately or repaired before the machine is used.**

4. Verify that the machine is in first-class condition and operating properly; shut off all power to the machine. Padlock all electrical and pneumatic energy in the off position and do not actuate the machine again until the installation of all package components has been completed. Lockout/tagout energy isolation procedures must always be practiced and enforced.

# SECTION 1—IN GENERAL

---

## Adjustable Stroke Detect-A-Finger® Drop-Probe Device

### General Overview

The adjustable stroke DAF-100 Detect-A-Finger® drop-probe device is an air/electric system. It is designed to effectively eliminate accidents that may arise when machine operators must have their fingers in close proximity to the point of operation on welder/riveter machines.

The DAF-100 is a safety device operated by air and cannot function without it.

### SYSTEM REQUIREMENTS

- Air .....35 psi @ 5 cfm minimum
- Electrical .....100-240 V AC, 47-63 Hz @ 1 Amp
- Relay output contacts .....5 Amps @ 250 V (Terminals 15-16 and 17-18)

### SEQUENCE OF OPERATION

Upon actuation of the foot switch, the sensing probe travels downward toward the workpiece. As long as there are no obstructions detected by the sensing probe, the machine will complete its cycle. If the sensing probe detects an obstruction (down to ¼" above the workpiece), the machine will not be allowed to complete its cycle. Clear the obstruction and reactuate the foot switch to complete the machine cycle.



**The sensing probe must be set to the proper safety distance—¼" above the workpiece.**

*Note: For two-stage machine operation, actuating the foot switch beyond first-stage operation will initiate second-stage operation once the sensing probe detects that it is free from obstructions.*

# SECTION 2—INSTALLATION OF COMPONENTS

Adjustable Stroke Detect-A-Finger® Drop-Probe Device

## Control Box

The DAF-100 system control box consists of an FTL-071 complete PC board which includes safety relays and pin-type plug-in terminals housed in an 8" x 6" NEMA enclosure. The control box should be mounted in a convenient location and should be mounted within two feet of the mini filter-regulator assembly. The area around the control box should be kept clear and be easily accessible for wiring and maintenance.



All electrical power and air supply to the machine must be off before mounting, wiring, or servicing the control box.

Outside View of DAF-100 Control Box



Inside View of DAF-100 Control Box

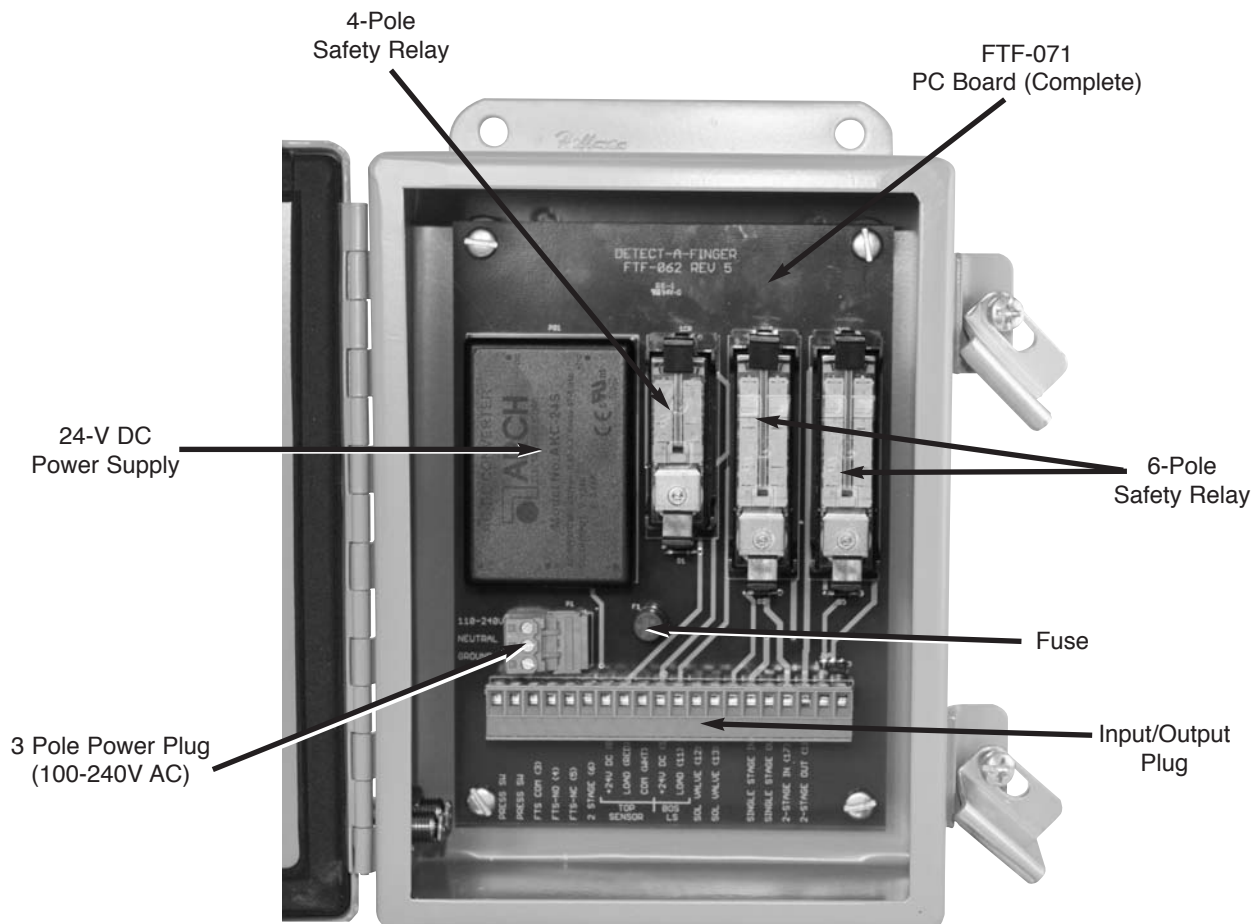

## SECTION 2—INSTALLATION OF COMPONENTS

### Adjustable Stroke Detect-A-Finger® Drop-Probe Device

## Mini Filter-Regulator Assembly

The mini filter-regulator assembly consists of one mini air filter and two mini air regulators. Each mini filter-regulator assembly is furnished with 25' of  $\frac{5}{32}$ " air tubing (PVC). This mini filter-regulator assembly is used to adjust the air pressure for the air cylinder inside the drop-probe assembly.

### INSTALLING THE MINI FILTER-REGULATOR ASSEMBLY

1. Drill and tap holes on the machine where the mini filter-regulator assembly is to be located (within 2 feet of the control box). Be careful when drilling holes into the frame of the machine. Avoid internal components that could affect machine operation.
2. Place one bolt and two  $\frac{1}{4}$ " flat washers (not furnished) to each of the four mounting feet on the mini filter-regulator assembly. These washers provide the necessary spacing for the tubing connectors on the back of the assembly. (See photo at right.)
3. Measure, cut, and connect two lengths of  $\frac{5}{32}$ " air tubing from the mini filter-regulator assembly to the air tube bulkheads on the outside of the control box. Make sure the air tube from the left side regulator is attached to the left air tube bulkhead.
4. Secure the mini filter-regulator assembly to the machine.

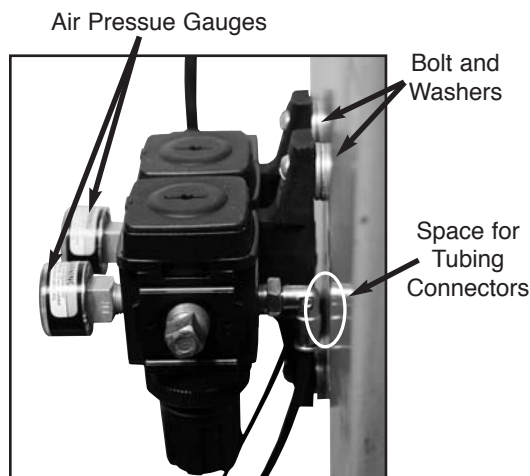

## Drop-Probe Assembly, PVC Insulator Block, and Sensing Probe

The drop-probe assembly consists of an air cylinder and solenoid operated air valve with an adjustable down stop locking collar, limit witch, and magnetic proximity switch inside a  $3\frac{1}{4}$ " x  $13\frac{3}{16}$ " enclosure. A PVC insulator block is also furnished with the assembly.

Drop Probe Assembly



Inside View of Drop-Probe Assembly

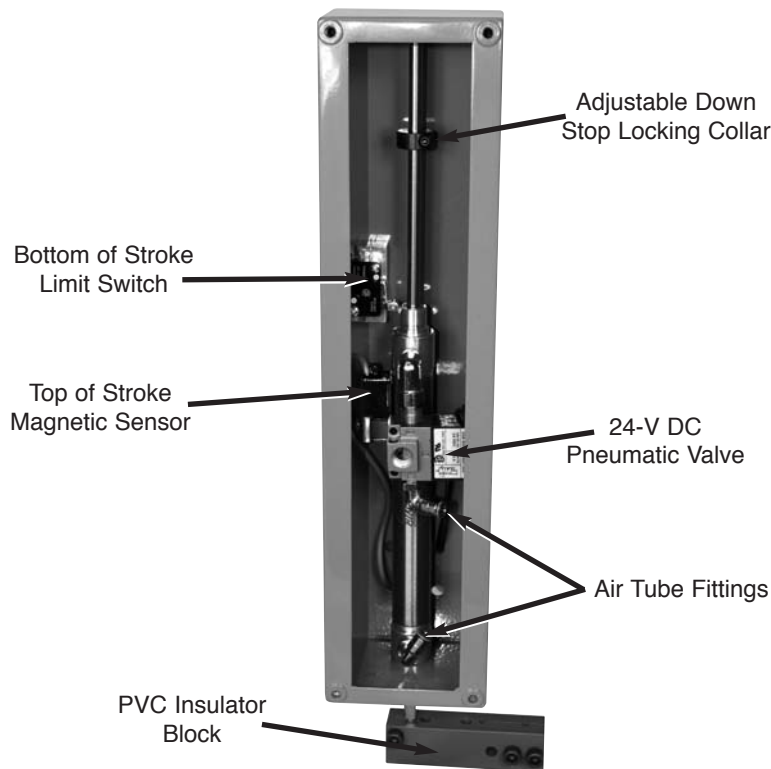

(Continued on next page.)

## SECTION 2—INSTALLATION OF COMPONENTS

Adjustable Stroke Detect-A-Finger® Drop-Probe Device

### INSTALLING THE DROP-PROBE ASSEMBLY, PVC INSULATOR BLOCK, AND SENSING PROBE

1. Loosely connect the PVC insulator block to the end of the cylinder rod on the bottom of the drop-probe box. Do not tighten all the way at this time.
2. Determine vertical or horizontal placement of the drop-probe box. Keep in mind that horizontal mounting will result in the 1" x 2" extrusion being mounted on the bottom rear of the drop-probe box. Mount the extrusion to the drop-probe box. (See photo below, left.)

**NOTE:** *For welder applications, do not mount the drop-probe box parallel to the upper armature plane. Fabricate a mounting bracket that will attach to the welder frame and run parallel to the bottom stationary armature instead. Mount the drop-probe box to this fabricated bracket.*

*For riveter applications, make sure the drop-probe box is mounted parallel to the vertical plane of the top riveting punch.*

3. While holding the drop-probe box with the extrusion to the mounting spot on the machine, angle the PVC insulator block towards the work surface. Make sure the air cylinder rod is fully retracted (up).
4. Secure the drop-probe box assembly to the machine (as close to the work surface as possible).

**NOTE:** *The sensing probe will add additional height to the overall mounting dimensions. If necessary, the PVC insulator block may be shortened by cutting off the first (outer) position where the sensing probe slides into the PVC block.*

**Do not** cut off the third hole between the outer and inner sensing probe mounting holes—the probe will not be able to be clamped tight!

5. Choose the sensing probe that best suits your application. (See example of sensing probe in photo below, right.) Shape (if using the aluminum probe) and install the sensing probe. To position the sensing probe, loosen the screw on the down stop locking collar and position the sensing probe so it is ¼" or less above the point of operation. Tighten the screw on the lock collar.
6. Tie off all wires and air tubes when finished so they do not come in contact with the adjustable down stop locking collar on the air cylinder.

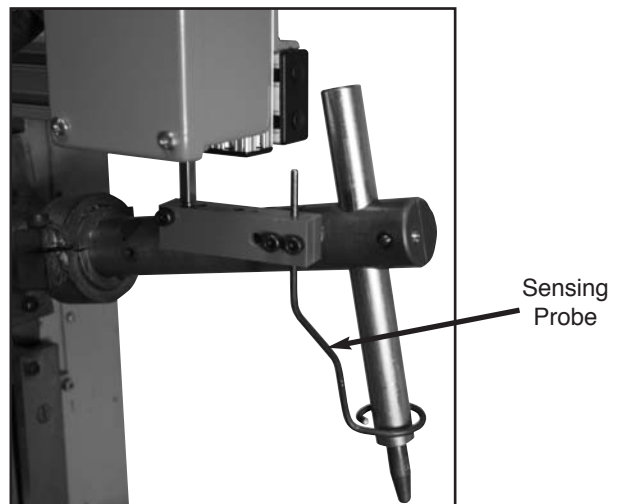
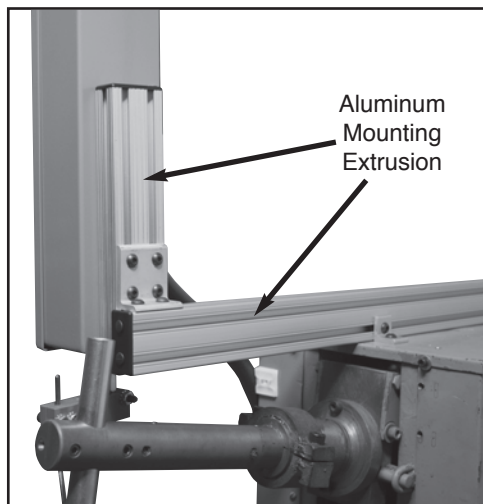

## SECTION 2—INSTALLATION OF COMPONENTS

---

### Adjustable Stroke Detect-A-Finger® Drop-Probe Device

## Wiring and Air Tube Connection

1. Remove the cover from the drop-probe assembly. Open the door of the control box. Measure and install ½" flexible conduit between the control box and drop-probe assembly.
2. Thread the magnetic sensor cable, 18-gauge blue stranded wire, and two ⅝" air tubes through the flexible conduit to the control box. Leave enough length out of each box to make it easier for connection. Number the blue wires according to the enclosed electrical schematics.
3. Trim and install all wires to the input/output plug (P2) on the circuit board in the control box.
4. Trim and connect the two air tubes to the two bulkheads on the outside of the control box.
5. Trim and connect all wires in the drop-probe assembly according to the enclosed electrical schematics.

**CAUTION** Turn the valves on the two mini regulators down before turning the main air valve on.

6. Turn on the main air valve and **slowly** increase the air pressure on the **left** mini regulator. Note which air tube in the drop-probe assembly is blowing the air and connect this tube to the **bottom** air fitting of the air cylinder.
7. Turn the main air supply valve off.
8. Trim and connect the remaining air tube to the air fitting located on the electrical air valve.
9. Tie off all wires and air tubes when finished so they do not come in contact with the adjustable down stop locking collar on the air cylinder.
10. Disconnect the existing foot switch from the machine making note of its location. Wire the foot switch to the input/output plug (P2) on the circuit board in the control box according to the enclosed electrical schematics.
11. In the vacated spot on the machine where the foot switch was originally connected, run new wires from this point on the machine to the input/output plug (P2) at terminals 15 and 16 on the circuit board of the control box. If the machine has a second-stage operation, run the necessary wires from the machine to the input/output plug (P2) at terminals 17 and 18 on the circuit board of the control box. Refer to the enclosed electrical schematics.

*Note: For welder applications, jumper "JMP" should be installed on pins 2 and 3.*

*For riveter applications, jumper "JMP" should be installed on pins 1 and 2.*

12. Run the appropriate machine power (100-240 V AC) and the ground wire into the Detect-A-Finger® control box. Connect these wires to plug P1 according to the enclosed electrical schematics.

## SECTION 2—INSTALLATION OF COMPONENTS

Adjustable Stroke Detect-A-Finger® Drop-Probe Device

### Other Components That May Be Required

If the machine being safeguarded with a DAF-series drop-probe Detect-A-Finger® has single-stroke capability, the following additional components may be required to trip or cycle the machine.

#### AIR CYLINDER (If furnished—See enclosed manual KSL-096)

An air cylinder can be used to convert mechanical operation of the machine to electro-pneumatic operation. The cylinder bore and stroke (pull- or push-type) can be determined from actual machine measurements and the location of attachment to the machine's linkage. The air cylinder is controlled by a dual-solenoid air valve; an air lockout valve is used to employ smooth arm movement; and a filter-regulator-lubricator assembly is also needed.

An RCL-series single-acting, spring-return air cylinder has a standard swivel-clevis mount. Mount the air cylinder in the most logical position so the yoke can be attached to the machine linkage, with the air inlet oriented toward the dual-solenoid air valve. **The main requirement for the air cylinder mounting location is that the piston rod will have a straight, inline pull (or push) when attached to the operating linkage.** Adjust so the air cylinder bottoms at the end of each stroke. Be sure the rod stroke is not too long because it could cause jackknifing of the cylinder. Also, too much air pressure may damage the operating linkage.

Make certain that the drive yoke and lock nut are located approximately halfway down on the threaded portion of the piston rod in order to provide up or down adjustment when necessary. Attach one end of the flexible rubber hose from the dual-solenoid air valve into the threaded inlet port on the air cylinder and tighten firmly.

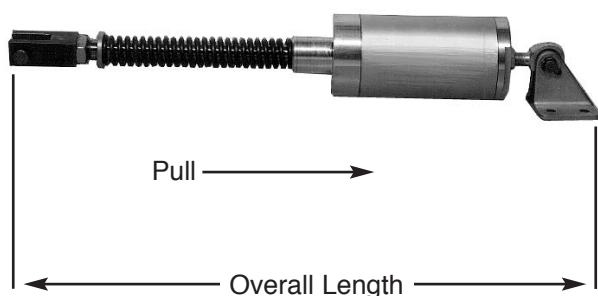

RCL-Series Air Cylinders

| Part Number | Bore (Inches) | Stroke (Inches) | Lbs. Pull (@ 75 PSI) | Overall Length |
|-------------|---------------|-----------------|----------------------|----------------|
| RCL-001     | 1.125         | 1.0             | 50                   | 10.25"         |
| RCL-002     | 1.500         | 1.0             | 100                  | 15.75"         |
| RCL-003     | 2.000         | 2.0             | 200                  | 19.75"         |

#### MONITORED DUAL-SOLENOID AIR VALVE (If furnished—See enclosed manual KSL-263)



Monitored Dual-Solenoid Air Valve Part No. RCD-116

This three-way, ¼" monitored dual-solenoid air valve is pneumatically checked and is used to operate an air cylinder. This dual-solenoid air valve should be mounted as close to the air cylinder as possible.



**The exhaust air muffler must be kept clean at all times. Never operate the machine unless the muffler is clean. The muffler must be cleaned on a regular basis.**



**For safety reasons, do not install any pneumatic devices between the dual-solenoid air valve and the air cylinder.**

#### SINGLE-SOLENOID AIR VALVE ASSEMBLY (If furnished—See enclosed manual KSL-151)



Single-solenoid Air Valve Assembly Part No. RCD-006

This single-solenoid air valve is a three-way, normally closed, quick-exhaust type. This assembly consists of the electric air solenoid valve, exhaust air muffler, steel mounting bracket, and flexible hose.



**The exhaust air muffler must be kept clean at all times. Never operate the machine unless the muffler is clean. The muffler must be cleaned on a regular basis.**

## SECTION 2—INSTALLATION OF COMPONENTS

Adjustable Stroke Detect-A-Finger® Drop-Probe Device

### FILTER-REGULATOR-LUBRICATOR (FRL) ASSEMBLY (If furnished—See enclosed manual KSL-208)



Filter-Regulator-Lubricator Assembly  
Part No. RCL-043

The filter cleans air that goes to the dual-solenoid air valve and air cylinder. The regulator and gauge are used to adjust air pressure. The lubricator keeps the dual-solenoid air valve and the air cylinder properly lubricated. The FRL assembly should be mounted in a convenient location on the machine, and if possible, it should be accessible from floor level. The lubricator should be filled with a good quality lubricant (see OEM's specifications) to the level indicated by the maximum fill line on the transparent reservoir. **Do not overfill.**



Never apply more than 145 psi.



The filter must be kept clean at all times. Never operate the machine unless the air filter is clean. The lubricator must not be filled while under pressure.



It is recommended that a manual shut-off valve be installed in the main line ahead of the filter-regulator-lubricator assembly and close to the machine for convenience and for locking out air.

### AIR LOCKOUT VALVE (If furnished—See enclosed manual KSL-098)

This ¼" air lockout valve is usually attached to the inlet end of an FRL assembly. This three-way valve is operated with the manual movement of a slide that opens and closes the valve. The valve can only be locked out when the slide is in the closed position. Downstream air is automatically exhausted when the valve is locked out.



Air Lockout Valve  
Part No. RCD-071

### FOOT SWITCH (If furnished—See enclosed manual KSL-001)



Foot Switch  
Part No. CTD-011

To meet OSHA and ANSI safety requirements, a foot switch must be protected from unintentional operation. This foot switch pedal is protected on the top and both sides by the cast cover and the front is protected by the hinged flap. Always follow the wiring schematics for proper wiring connection and be sure to maintain the foot switch in first-class condition.



It is the responsibility of the employer (user) to always provide an appropriate guard and/or device to prevent bodily injury whenever a foot switch is used to initiate a machine cycle.



The guard and/or device must be properly installed, used, and maintained. The safeguard must prevent personnel from receiving bodily injuries.

## SECTION 2—INSTALLATION OF COMPONENTS

*Adjustable Stroke Detect-A-Finger® Drop-Probe Device*

### Installation Considerations

#### PIPING

1. An air lockout valve must be installed in the air line usually just before the filter-regulator-lubricator assembly to meet OSHA 29 CFR 1910.147 Lockout/tagout requirements.
2. From the lockout valve, connect at the **In** threaded opening of the filter-regulator. Try to maintain an appropriate pipe size throughout for proper air flow. Connect the piping to the ports using teflon tape on the male threads only. Do not allow tape to enter the interior of the filter-regulator-lubricator, valve, or air cylinder. Before applying air pressure, make sure the filter and regulator bowls are at least hand tight.
3. Most approved pipe or hose can be used on the machine. Make sure the size is consistent throughout the system in order to avoid restriction. Keep air runs as short as possible.
4. See enclosed filter-regulator-lubricator (FRL) assembly Manual No. KSL-208 for additional details.

**All air components require clean air. Blow all lines clean of water, dirt, scale, etc., before making final connection. Drain water from filter bowl regularly. Should this bowl refill in a short period of time, it may indicate the need for a larger filter in the main air supply line or an air line dryer system. The air filter must be kept clean at all times. Never operate the machine unless the air filter is clean and water is drained.**

#### CAUTION

#### WIRING

National Electrical Code and NFPA 79 practices are usually followed for wiring the control system, which includes color-coding and the use of numbered wire markers on **both ends of every wire**. Color-coding is black for power circuits, red for 120-V AC control circuits, white for current-carrying ground (commonly referred to as the neutral), and green for any equipment grounding conductor.

The size of wire depends on local ordinances. Number 14 stranded copper wire with an approved insulation is recommended. **Do not use solid wire.**

Rigid, Sealtite, or any tubular connection media that complies with local ordinance is satisfactory. Complete wiring diagrams are provided for connecting the control and components.

## SECTION 3—POWER-UP PROCEDURES

Adjustable Stroke Detect-A-Finger® Drop-Probe Device

### Power-Up Procedures



Proceed with caution when performing the power-up procedures. The machine may cycle unexpectedly.

1. Turn the main electrical power and the main air valve to the machine on.
2. On the mini filter-regulator assembly, set the air pressure on the left regulator to about 15 PSI and the right regulator to 0. The air cylinder in the drop-probe assembly should be fully retracted (up). If the air cylinder is not in the retracted position, turn off the air supply and reverse the two air tubes going into the air bulkheads on the outside of the control box. Turn the air supply back on and verify the air cylinder is in the up position.
3. Actuate the foot switch. The machine should not cycle at this time. If the machine cycles unexpectedly, verify the air pressure on the right regulator is turned all the way off and that the air cylinder in the drop-probe assembly is in the up position. If the air cylinder in the drop-probe assembly does not move when the foot switch is actuated, recheck all wiring and air connections. Correct any mistakes before proceeding.
4. While actuating the foot switch (and the machine not cycling), slowly increase the air pressure on the right regulator of the mini filter-regulator assembly until the air cylinder extends. The machine should cycle at this time.

*NOTE: For welder applications, the sensing probe should extend down to the preset stop position and then immediately return to top.*

*For riveter applications, the sensing probe should extend down to the preset stop position and remain down through the entire machine cycle.*

5. Verify that all is functioning correctly and then adjust the air pressure on the left and right regulators to increase the speed of air cylinder operation. **Use small increments when adjusting the regulators.**

#### CAUTION

Always try to use the least amount of air pressure on the drop-probe assembly air cylinder. Excessive air pressure could cause the sensor wire to bend out of shape.

6. Insert the workpiece into the machine and actuate the foot switch. Verify that the sensing probe is stopping at the mandatory ¼" above the point of operation. Make adjustments to the lock collar if necessary.
7. After all adjustments are made, verify that the Detect-A-Finger® drop-probe device is working properly. Place an inanimate object—**NOT A FINGER**—between the workpiece and sensing probe. Actuate the foot switch and verify that the machine does not cycle.



Do not use a finger as a test object—always use an inanimate object. Do not place the test object under the moving part of the machine.

8. When verification is complete, you are now ready for production.

## SECTION 4—TROUBLESHOOTING

### Adjustable Stroke Detect-A-Finger® Drop-Probe Device



#### **SYMPTOM 1**

After turning on the air supply (but not the electrical power), the sensing probe travels to bottom of stroke.

#### **SOLUTION**

Verify all electrical power to the machine is turned off and verify this by using an electrical volt meter. Verify the air supply to the machine is turned on.

Make sure the right-hand side of the mini air filter-regulator assembly (feeding the drop-probe assembly) is adjusted down to 0 PSI and the left-hand side is set to around 15 PSI. (Turn adjustment knob counter-clockwise to decrease air pressure and clockwise to increase air pressure.) Verify the air tubes are going to the proper locations on the air cylinder in the drop-probe assembly. Depress the tubing release ring of the bottom 90° air-tube fitting on the air cylinder and remove the air tube. Depress the tubing release ring of the top 90° air-tube fitting on the air valve and remove the air tube. Install the tube that is blowing air to the bottom 90° air-tube fitting on the air cylinder. Install the remaining air tube to the top 90° air-tube fitting on the air valve.



#### **SYMPTOM 2**

After turning on electrical power (without actuating the foot switch), the sensing probe travels to bottom of stroke.

#### **SOLUTION**

Verify SYMPTOM 1 is not the cause of the problem before proceeding.

Open the door on the main control box. Using a volt meter set on DC scale, check the DC voltage on terminal 4 (FTS NO) on the P2 connector plug in reference to any terminal 9, 12, or 14 on this same plug (refer to electrical schematics). The meter should read 0 DC volts. If not, remove electrical power to the machine and recheck the wiring connections on the foot switch limit switch contacts to the P2 connector plug.

The 'com' terminal on the foot switch limit switch must be wired to terminal 3 on P2 connector (FTS COM), the NO contact on the foot switch limit switch must be wired to terminal 4 on P2 connector (FTS NO). The NC contact on this limit switch must be wired to terminal 5 on P2 connector (FTS NC). Verify that the wiring from the air valve is connected to terminals 12 and 13 on P2 connector.

Turn on the electrical power again (do not actuate the foot switch). Does the air cylinder still travel to bottom of stroke? If YES, check the voltage on terminals 12 and 13 on P2 connector. The meter should read 0 DC volts. If the meter reads 0 DC volts, replace the electrical air-solenoid valve in the drop-probe assembly.



#### **SYMPTOM 3**

After turning on the electrical power and air supply, the sensing probe does not go to bottom of stroke when the foot switch is actuated.

#### **SOLUTION**

Before proceeding, verify SYMPTOMS 1 and 2 are not the cause of this problem. Open the door on the control box. Actuate the foot switch to the middle position if the machine has a two-stage operation, or all the way down for single-stage operation. Check the DC voltage on terminal 12 and 13 on P2 connector. The meter should read +24 volts DC. If the meter reads +24 volts DC, turn off electrical power to the machine and check the wiring again or replace the air-solenoid valve in the drop-probe assembly.

## SECTION 4—TROUBLESHOOTING

---

### Adjustable Stroke Detect-A-Finger® Drop-Probe Device



#### SYMPTOM 4

After depressing the foot switch, the sensing probe goes to bottom of stroke but the machine will not cycle.

#### SOLUTION

Open the door of the control box. Actuate the foot switch to the middle position if the machine has a two-stage operation, or all the way down for single-stage operation. Check the DC voltage on terminal 9 and 11 on P2 connector. The voltage on terminal 11 should read +24 volts DC. If not, completely release the foot switch and check the voltage on terminal 11 again. If the meter now reads +24 volts DC when the probe is in the up position, one of the wires on the mini limit switch inside the drop-probe assembly is connected to the NC contact. Turn off all electrical power to the machine, remove the door of the drop-probe assembly, and connect the mini limit switch wire to the proper NO contact.

Once the above problem is corrected, actuate the foot switch to the middle position or all the way down. The device should now be at the bottom of the stroke. Verify that the down stop locking collar is completely down and resting against the top of the air cylinder. **The down stop locking collar must be down against the top of the air cylinder before the machine can cycle.** If the down stop locking collar is all the way down and touching the air cylinder, the mini limit switch may need to be adjusted slightly. *Note: This adjustment is very sensitive and should not require much movement.* Slightly loosen the two 10-32 hex head screws on the back of the drop-probe assembly and move the limit switch mounting block closer towards the clamp collar. Retighten the two 10-32 hex head screws. When the limit switch mounting bracket is properly adjusted, you should hear a slight click sound just before the clamp collar is completely down against the top of the air cylinder. If the limit switch is adjusted too far in, it will cause the normal cycle of the machine to begin before the sensing probe is at its lowest point. This may be an unsafe condition for the operator.

If the machine still does not cycle, check that outputs (terminals 15-16 and 17-18 on P2 connector) are properly interfaced into your machine cycle control circuit. These outputs are dry contacts and may be used with 24 V DC or 115/240 V AC.

# SECTION 5—REPLACEMENT PARTS

## Adjustable Stroke Detect-A-Finger® Drop-Probe Device

### Main Control Box

| Part No | Description        |
|---------|--------------------|
| CCM-037 | 3-Pin Power Plug   |
| CCM-058 | 20-Pin IO Plug     |
| FTL-071 | PC Board, Complete |
| RTY-026 | Fuse, .500ma       |
| RYC-041 | 2-Pin Shunt        |

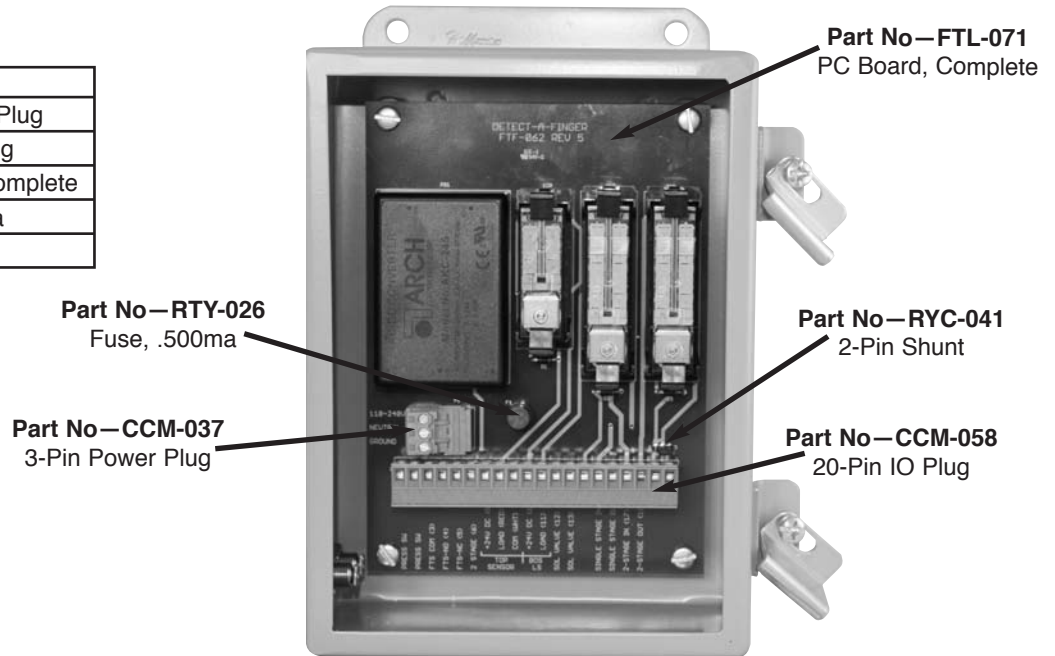

### Drop-Probe Assembly and Mini Air Filter/Regulator

| Part No.     | Description                      |
|--------------|----------------------------------|
| 3A583        | 5/32" T-Handle Hex Wrench        |
| 9081145      | Mini Limit Switch                |
| D108836A     | Bimba Double Ended Air Cylinder  |
| DAF100-03    | Limit Switch Mounting Bracket    |
| DAF100-04    | PVC Insulator Block              |
| DAF100-19    | Top of Stroke Magnetic Sensor    |
| DAF100-20    | Air Pressure Gauge, Center Mount |
| DAF100-21    | Pneumatic Valve                  |
| FCT-030      | Sensing Probe, 5/32 x 18" L      |
| FRE1J18901   | 25' of 5/32" Air Tubing          |
| IL656        | Lock Collar                      |
| WILR0802SR00 | Mini Air Filter                  |
| WILR0902FB00 | Mini Air Regulator (each)        |

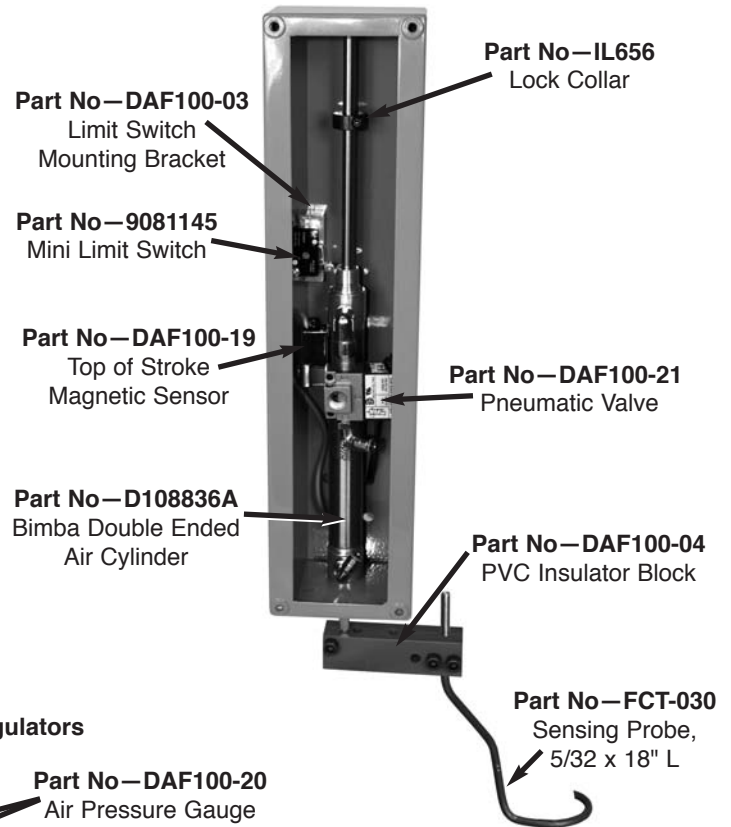

### Mini Air Filter and Air Regulators



## ORDER FORM FOR SIGNS AND LITERATURE

This instruction manual references signs and literature available for your machines. This order form is for your convenience to order additional signs and/or literature as needed. (This order form is part of your installation manual so please make a copy of it when ordering.)

Company \_\_\_\_\_

Address \_\_\_\_\_

City \_\_\_\_\_ State \_\_\_\_\_ Zip \_\_\_\_\_

Phone \_\_\_\_\_ Fax \_\_\_\_\_

Name \_\_\_\_\_ Purchase Order No. \_\_\_\_\_ Date \_\_\_\_\_

| Part No. | Description                                  | Quantity Required |
|----------|--|-------------------|
| KSL-280  | Installation Manual                          | _____             |
| KSC-000  | Operator Safety Precaution Sign (English)    | _____             |
| KSC-000S | Operator Safety Precaution Sign (Spanish)    | _____             |
| KSC-000F | Operator Safety Precaution Sign (French)     | _____             |
| KSC-055  | Danger Sign (Foot Switch) 5" x 6" (English)  | _____             |
| KSC-055S | Danger Sign (Foot Switch) 5" x 6" (Spanish)  | _____             |
| KSC-055F | Danger Sign (Foot Switch) 5" x 6" (French)   | _____             |
| KSL-051  | <i>Mechanical Power Press Safety Booklet</i> | _____             |
| KST-346  | Detect-A-Finger® Label (Front Cover)         | _____             |

For prices and delivery, please use address, phone or fax number listed on the front cover of this manual.

Your Signature \_\_\_\_\_ Date \_\_\_\_\_

## RETURN MATERIALS AUTHORIZATION REQUEST FORM

To return material for any reason contact the sales department in our organization at 1-800-922-7533 for an RMA Number. All return materials shipments must be prepaid. Complete this form and send with material to 4620 Hydraulic Road, Rockford, IL 61109-2695. Make sure the RMA Number is plainly identified on the outside of the shipping container.

Company \_\_\_\_\_

Address \_\_\_\_\_

City \_\_\_\_\_ State \_\_\_\_\_ Zip \_\_\_\_\_

Phone \_\_\_\_\_ Fax \_\_\_\_\_

Contact Name \_\_\_\_\_ Representative \_\_\_\_\_

Items Authorized To Return on RMA No. \_\_\_\_\_ Original Invoice No. \_\_\_\_\_ Date \_\_\_\_\_

Part No. \_\_\_\_\_ Serial No. \_\_\_\_\_ Description \_\_\_\_\_

Service Requested:  Full Credit  25% Restocking  Repair & Return  Warranty Replacement

Reason for return (describe in detail): \_\_\_\_\_

\_\_\_\_\_

Return Materials Authorized By \_\_\_\_\_ Date \_\_\_\_\_