

Introduction

According to OSHA 29 CFR 1910.217, “The employer shall provide and enforce the use of safety blocks for use whenever dies are being **adjusted** or **repaired** in the press.” They are not required during die setting unless die blocks are included in your die setting procedure. They also satisfy the lockout/tagout requirements for isolating mechanical energy.

Die safety blocks are placed between the die punch and holder with the machine stroke up. They are rated to support a static load. The static load represents the combined weight of the press ram, ram components (ram-adjust assembly and connection rod[s] or pitman arm[s]), and the upper die.

In some applications, as many as four safety blocks may be required. This is determined by the size of the press bed and the weight the blocks must support. On larger presses, the total slide weight must then be distributed among the quantity of safety blocks required.

The ram is usually adjustable; therefore, wedges or the adjustable screw device is offered to provide a proper fit. If the die takes up most of the space on the die set, it may be difficult to find a place to insert the block. To avoid accidentally stroking the press or leaving the safety block in the die after use, an electrical power cut-off interlock system should be used.

Note: Electrical interlocking of die safety blocks to the machine’s motor and control circuits is required by ANSI B11.19.

ALUMINUM DIE SAFETY BLOCK SYSTEM

This high-strength die safety block is lightweight and comes in several sizes. The unique shape and mechanical properties of the 6061-T6 material have been calculated according to stringent structural aluminum design analysis standards to provide high strength.

To determine the number of die safety blocks required, the static load each die safety block will support, and the length of each block, please follow the instructions below and on the next page.

1. Determining the static load the die safety block(s) will support:

The actual static load that the die safety block(s) will support is determined by adding the actual weights of the press slide and slide components (ram-adjustment assembly, connection rod[s] or pitman arm[s], and the upper die).

If this weight cannot be determined, an approximate static load can be calculated using the information and formulas on the next page.

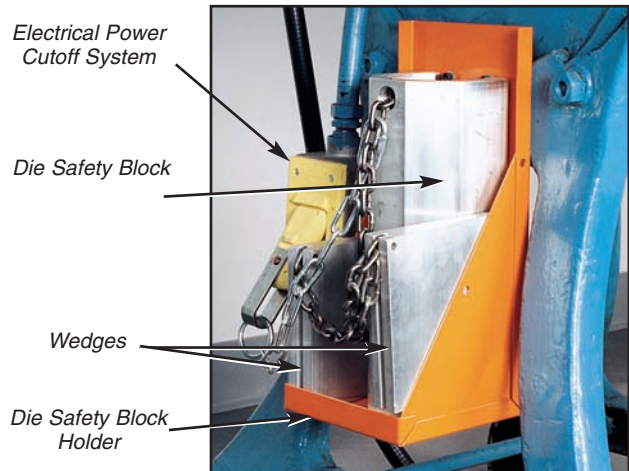

U-Shaped Safety Block in Holder With Wedges and Electrical Power Cutoff System

SHUT HEIGHT, 3 (DIE SPACE), ON MECHANICAL POWER PRESSES AND LOCATION OF SLIDE (BETWEEN 1 AND 2) WHEN APPLYING DIE SAFETY BLOCKS

- 1 S.U.A.U. - Stroke Up - Adjustment Up
 - 2 S.U.A.D. - Stroke Up - Adjustment Down
 - 3 S.D.A.U. - Stroke Down - Adjustment Up
 - 4 S.D.A.D. - Stroke Down - Adjustment Down
- SHUT HEIGHT**

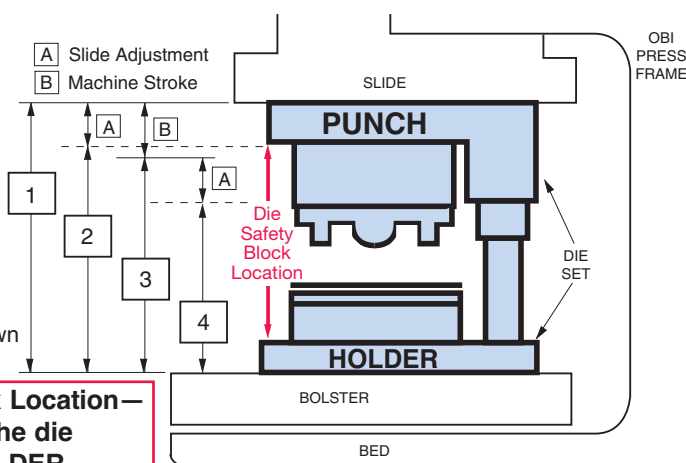

Die Safety Block Location—Place between the die PUNCH and HOLDER.

Allow 2000 pounds of static load for each cubic foot displaced in the press bed area (front to back x right to left) multiplied by the shut height (die space) of the press. *Note: When using this formula, the calculated approximated static load has a safety factor of two (2).*

Formulas:

$$\frac{\text{Press Bed Area (sq in)} \times \text{Shut Height (in)}}{\text{Cubic Inches/Cubic Feet (Constant)}} = \text{Cubic Feet Displaced}$$

(1728 cu in/cu ft)

$$\text{Cubic feet displaced} \times 2000 \text{ lb/cubic foot} = \text{Total Static Load}$$

Example:

$$\frac{(\text{Press Bed Area}) (\text{Shut Height})}{1728 \text{ cu in/cu ft}} = \frac{110,592}{1728} = 64 \text{ cu ft}$$

$$64 \text{ cubic feet displaced} \times 2000 \text{ lb/cu ft} = 128,000 \text{ lb static load}$$

2. Determining the Die Safety Block Length

With the machine at the top of its stroke; stroke up—adjustment up (S.U.A.U.—see previous page), measure the space between the upper and lower die set plates (not the distance between the bolster and slide). This gives the maximum safety block length. To determine the stroke up—adjustment down (S.U.A.D.—see previous page) measurement, subtract the ram adjustment from the S.U.A.U. figure. This provides the minimum length of the die safety block.

Total Length of Die Safety Block Required _____ "

EXCEPTIONS

A. If wedges will be used, subtract 1½" maximum. This is an allowance for variation in the stopping point of the crankshaft or adjustment of the ram.

Total Length of Die Safety Block Required _____ "

B. When an adjustable screw is added to an octagonal safety block, the **minimum length of the aluminum portion of the safety block** is as follows:

For small and medium safety blocks

2½" plus the size of the adjustable screw device

For large safety blocks

3" plus the size of the adjustable screw device

When an adjustable screw device is added to an octagonal safety block and the screw is all the way inside of the safety block, **it will add 2" to the overall length of small and medium safety blocks and 2½" to the overall length of large safety blocks.** Therefore, subtract 2" for small or medium blocks and 2½" for large blocks to determine the length of the aluminum portion of the die block.

Example: If the minimum overall length of the small or medium safety block required is 10½" with any size adjustable screw device, the aluminum portion of the safety block would be 8½" (10½" - 2" = 8½").

Example: If the minimum overall length of the large safety block required is 16" with any size adjustable screw device, the aluminum portion of the safety block would be 13½" (16" - 2½" = 13½").

Total Length of the Aluminum Portion of the Die Safety Block _____ "

3. Determining the Size of the Die Safety Block

The size of the die safety block (small, medium, large) is determined by one or both of the following factors:

- A.** The size of the block itself and the area available in the die. (See static load charts.)
- B.** The static load capacity of the block (small, medium, large) versus the total static load being supported. (See static load charts.)

Safety Blocks

X-SHAPED SAFETY BLOCKS

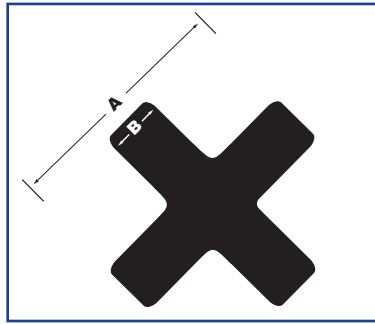

	Small	Large
A	4"	5 ³ / ₄ "
B	1"	1 ¹ / ₄ "

Weight of Blocks	
Small	0.681 lb/in
Large	1.250 lb/in

Maximum Approximate Static Load Per Block in Pounds (Tons)*

Block Length	Small	Large
1"-24"	97,000 (48)	203,000 (101)
24 ¹ / ₂ "-30"	90,000 (45)	189,000 (94)
30 ¹ / ₂ "-36"	86,000 (43)	171,000 (85)
36 ¹ / ₂ "-42"	84,000 (42)	169,000 (84)
42 ¹ / ₂ "-48"	73,000 (36)	165,000 (82)
48 ¹ / ₂ "-54"	71,000 (35)	146,000 (73)
54 ¹ / ₂ "-60"	69,000 (34)	144,000 (72)

*The approximate static loads shown in this chart have a built-in safety factor of two.

To determine the number of safety blocks required, the static load each safety block will support, and the length of each block, please refer to pages 2-3.

The X-shaped safety blocks can be furnished four different ways:

- A)** Cut to length with a hole and pin for an interlock chain or wedges
- B)** Cut to length only
- C)** In a nine-foot length
- D)** Cut to length with a hole and pin for an interlock chain or wedges and a base plate installed (order base plate separately; see page 6)

	Small	Large
Way Furnished†	Part No.	Part No.
A	KTS-609	KTS-610
B	KTS-605	KTS-606
C	KTS-607	KTS-608
D	KTS-635	KTS-636

†Powder coating available on request—please consult the factory.

U-SHAPED SAFETY BLOCKS

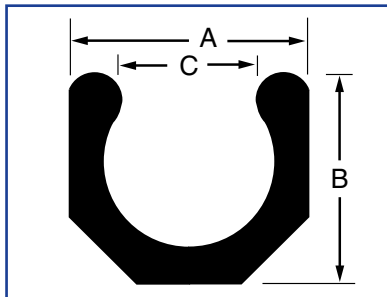

	Small	Medium	Large
A	4 ⁵ / ₈ "	5 ¹ / ₂ "	6 ³ / ₄ "
B	4"	4 ⁷ / ₈ "	5 ¹ / ₂ "
C	2 ⁵ / ₈ "	3 ¹ / ₄ "	4 ¹ / ₄ "

	Maximum Approximate Static Load Per Block in Pounds (Tons)*		
Block Length	Small	Medium	Large
1"-24"	88,500 (44)	126,000 (63)	169,500 (84)
24 ¹ / ₂ "-30"	87,000 (43)	123,000 (61)	166,000 (83)
30 ¹ / ₂ "-36"	84,000 (42)	120,500 (60)	162,000 (81)
36 ¹ / ₂ "-42"	81,500 (40)	117,500 (58)	159,000 (79)
42 ¹ / ₂ "-48"	79,000 (39)	114,000 (57)	156,000 (78)
48 ¹ / ₂ "-54"	76,500 (38)	112,000 (56)	152,000 (76)
54 ¹ / ₂ "-60"	74,000 (37)	108,500 (54)	148,500 (74)

*The approximate static loads shown in this chart have a built-in safety factor of two.

Weight of Blocks	
Small	0.638 lb/in
Medium	0.879 lb/in
Large	1.17 lb/in

To determine the number of safety blocks required, the static load each safety block will support, and the length of each block, please refer to pages 2-3.

The U-shaped safety blocks can be furnished three different ways:

- A)** Cut to length with a hole and pin for an interlock chain or wedges
- B)** Cut to length only
- C)** In a nine-foot length

	Small	Medium	Large
Way Furnished†	Part No.	Part No.	Part No.
A	KTS-561	KTS-562	KTS-563
B	KTS-564	KTS-565	KTS-566
C	KTS-554	KTS-555	KTS-556

†Powder coating available on request—please consult the factory.

OCTAGONAL SAFETY BLOCKS

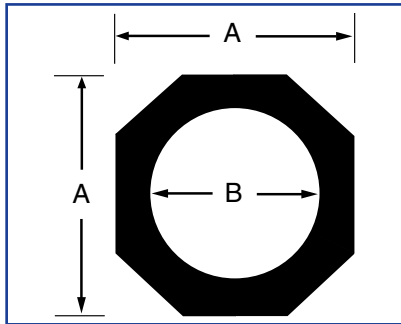

	Small	Medium	Large
A	4 ⁵ / ₈ "	5 ¹ / ₂ "	6 ³ / ₄ "
B	3 ¹ / ₂ "	4 ¹ / ₄ "	5 ¹ / ₄ "

Block Length	Maximum Approximate Static Load Per Block in Pounds (Tons)*		
	Small	Medium	Large
1"-24"	190,000 (95)	275,500 (137)	289,500 (144)
24 ¹ / ₂ "-30"	173,000 (86)	258,000 (129)	258,000 (129)
30 ¹ / ₂ "-36"	169,500 (84)	244,000 (122)	245,000 (122)
36 ¹ / ₂ "-42"	164,500 (82)	232,000 (116)	234,500 (117)
42 ¹ / ₂ "-48"	158,000 (79)	226,500 (113)	223,500 (111)
48 ¹ / ₂ "-54"	155,500 (77)	226,000 (113)	211,000 (105)
54 ¹ / ₂ "-60"	155,000 (77)	218,500 (109)	210,500 (105)

*The approximate static loads shown in this chart have a built-in safety factor of two.

Weight of Blocks	
Small	0.833 lb/in
Medium	1.12 lb/in
Large	1.58 lb/in

To determine the number of safety blocks required, the static load each safety block will support, and the length of each block, please refer to pages 2-3.

The octagonal safety blocks can be furnished four different ways:

- A) Cut to length with a hole and pin for an interlock chain and with an adjustable screw device and/or base plate installed (order adjustable screw device and/or base plate separately; see below and page 6)
- B) Cut to length with a hole and pin for an interlock chain or wedges
- C) Cut to length only
- D) In a nine-foot length

Way Furnished†	Small	Medium	Large
	Part No.	Part No.	Part No.
A	KTS-589	KTS-590	KTS-591
B	KTS-592	KTS-593	KTS-594
C	KTS-595	KTS-596	KTS-597
D	KTS-599	KTS-600	KTS-601

†Powder coating available on request—please consult the factory.

ADJUSTABLE SCREW DEVICE—FOR USE WITH OCTAGONAL SAFETY BLOCKS ONLY

This heavy-duty steel screw device is added to the octagonal shaped safety blocks. These screws are needed to prevent any space between the block and die when various dies are used or when the slide is adjusted.

Note: If an adjustable screw device is mounted to an octagonal safety block, you must use the approximate static loads shown in the chart. This is because the adjustable screw devices will not hold as heavy a static load as the octagonal safety blocks by themselves.

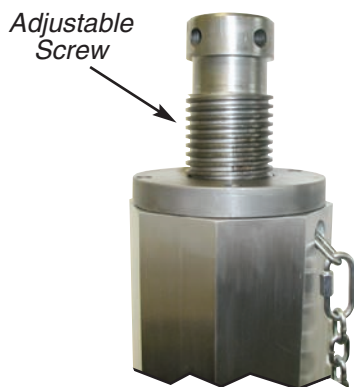

Adjustable Screw Device			
Octagonal Safety Block Size	Inches of Adjustment	Part No.	Maximum Approximate Static Load Per Adjustable Screw Device in Pounds (Tons)*
Small	2"	KTS-574	106,000 (53)
	4"	KTS-584	102,500 (51)
	6"	KTS-625	98,500 (49)
	8"	KTS-626	94,500 (47)
	10"	KTS-627	91,000 (45)
Medium	12"	KTS-622	87,500 (43)
	2"	KTS-575	73,000 (36)
	4"	KTS-585	70,000 (35)
	6"	KTS-628	67,000 (33)
	8"	KTS-629	64,000 (32)
Large	10"	KTS-630	61,000 (30)
	12"	KTS-623	58,000 (29)
	6"	KTS-598	189,000 (94)
	8"	KTS-631	181,000 (90)
	10"	KTS-632	174,000 (87)
	12"	KTS-624	167,000 (83)

*The approximate static loads shown in this chart have a built-in safety factor of two.

Safety Block Accessories

SAFETY BLOCK BASE

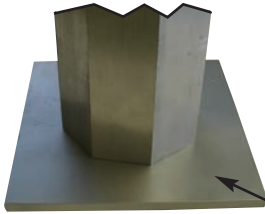

This safety block base can be added to U-shaped, octagonal-shaped, and X-shaped safety blocks. The base adds stability to help prevent the die block from tipping over. **Available in ½" thick steel or aluminum.**

Safety Block Base

Steel Bases for U-Shaped and Octagonal-Shaped Safety Blocks		
Part No.	Description	Dimensions
STL-053	Mini base	6" x 6"
STL-049	Small base	8 ⁵ / ₈ " x 8 ⁵ / ₈ "
STL-050	Medium base	9 ¹ / ₂ " x 9 ¹ / ₂ "
STL-051	Large base	10 ³ / ₄ " x 10 ³ / ₄ "

Steel Bases for X-Shaped Safety Blocks		
Part No.	Description	Dimensions
STL-057	Small X-base	4" x 4"
STL-058	Large X-base	6" x 6"

Aluminum Bases for Octagonal-Shaped Safety Blocks		
Part No.	Description	Dimensions
KTS-638	Small base	6" x 6"
KTS-640	Medium base	8" x 8"
KTS-641	Large base	10" x 10"

Aluminum Bases for X-Shaped Safety Blocks		
Part No.	Description	Dimensions
KTS-637	Small X-base	4" x 4"
KTS-639	Large X-base	6" x 6"

SAFETY WEDGES

These wedges prevent hazardous movement of the press slide if a space is created between the block and die when various dies are used or when the slide is adjusted. All cut-to-length wedges are furnished with a 24" chain. **Available in aluminum or hardwood.**



Safety Wedges for Safety Blocks	
Part No.	Description
KTS-571	6" aluminum wedge for small blocks
KTS-572	7" aluminum wedge for medium blocks
KTS-573	8" aluminum wedge for large blocks
KTS-570	Aluminum wedge material in a 9' length
KTS-642	Hardwood wedge for all block sizes

HOLDERS

These holders are designed to accept U-shaped, octagonal, X-shaped, and adjustable safety blocks. They are constructed of heavy-gauge steel and painted safety orange. The holders attach easily to the machine with two ¼" fasteners. A strap is furnished with each holder to keep the block in place. Safety wedges can also be stored in the holders.



Holders	
Part No.	Dimensions
KTS-003	8" x 8" x 14"
KTS-005	10 ¹ / ₂ " x 10 ¹ / ₂ " x 14"
KTS-019	10 ¹ / ₂ " x 10 ¹ / ₂ " x 24"
KTS-020	12" x 12" x 30"

LIFTING HANDLE—PART NO. KTS-633

The aluminum lifting handle is a convenient option for all safety blocks that are used frequently.



ELECTRICAL INTERLOCK SYSTEMS

According to ANSI B11.19-2003, safety blocks "shall be interlocked with the machine to prevent actuation of hazardous motion of the machine." The following interlock systems will satisfy this requirement. The interlock must be interfaced into the control system so that when the plug is pulled, the power to the main drive motor and control is disconnected. If the machine has a mechanical energy source, such as a flywheel, it must come to rest before the die block can be inserted. The interlock system is available in a yellow plug with one contact or an orange plug with two contacts. The interlock system includes the plug, a 12" or 24" long chain, a receptacle, and an electrical mounting box.



Part No. KTS-503

One-contact interlock system with 12" chain

Part No. KTS-518

One-contact interlock system with 24" chain

Part No. KTS-534

Two-contact interlock system with 12" chain

Part No. KTS-533

Two-contact interlock system with 24" chain

WARNING LABELS—PART NO. KST-323—English PART NO. KST-323S—Spanish

The warning label illustrated to the right is provided with all safety blocks and should be affixed directly to each safety block. If a safety block is not tall enough for the label to fit, affix it to a prominent location on the machine. All personnel operating or working around the machine must be required to read, understand, and adhere to all warnings on this label. If the label becomes destroyed or unreadable, it **MUST** be replaced. Contact the factory immediately for a replacement label and do not operate the equipment until the warning label is in place.

⚠ WARNING

This is a static-load safety block (it will not hold the full working force of the machine). Before use, make sure that it (and any other blocks to be used) will support two (2) times the static load of the moveable portion of the machine, its tooling, and attachments.

DO NOT use this safety block unless it has been electrically interlocked with the machine's main drive motor or control system.

DO NOT use this safety block until all energy is dissipated (e.g., until the flywheel is at rest).

NEVER place this safety block on an edge where it is partially unsupported.

NEVER leave any remaining space between the safety block and the machine or die members to be held.

ALWAYS place this safety block into the die or tooling when adjusting or repairing dies in the machine.

ALWAYS remove this safety block before starting the machine.

FAILURE to obey could result in death or serious injury.

This sign does not cover all dangers that could happen while using this safety block and operating the machine.

Label No. KST-323

MAXIMUM LOAD LABEL—PART NO. KST-330

The maximum load label shown to the right is provided with all safety blocks and is affixed directly to each safety block. If the label becomes destroyed or unreadable, contact the factory for a replacement label. The maximum load in tons should be written legibly on the label in permanent marker based on the maximum load chart.

MAX. LOAD

TONS

Label No. KST-330

ADJUSTABLE DIE SAFETY BLOCKS



These adjustable safety blocks feature a tough malleable-iron bell-bottom base, a convenient handle for lifting, and precision-cut acme threads for easy adjustment and extra rigidity. The adjusting screw can be easily adjusted up or down by hand. Turning holes are also provided in the screw neck to facilitate the use of a turning bar, if required.

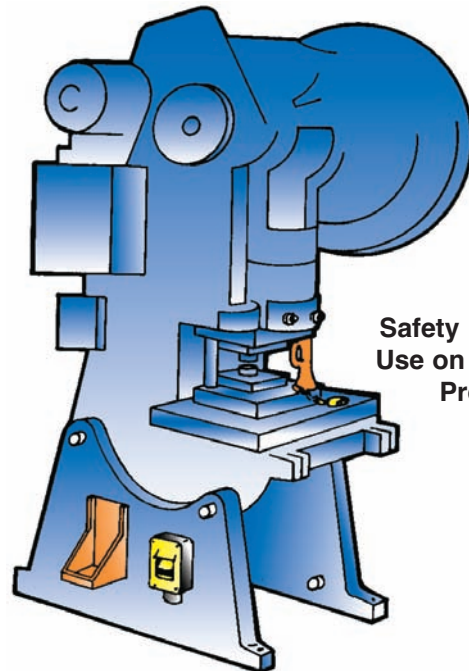

Safety Block in Use on a Power Press

Part No.	Capacity in Tons	Length Closed	+ Screw Adjustment	+ Length Screw Adjustment Up	Base Diameter	Weight in Pounds	Safety Block Holder Part No.
KTS-520*	10	6 ³ / ₄ "	1 ¹ / ₄ "	8"	4 ⁷ / ₈ "	8	KTS-003
KTS-521	10	8 ³ / ₄ "	3 ¹ / ₂ "	12 ¹ / ₄ "	5 ⁵ / ₈ "	10	KTS-003
KTS-522	10	12 ³ / ₄ "	7 ¹ / ₄ "	20"	6 ¹ / ₂ "	13	KTS-003
KTS-523	20	9 ¹ / ₂ "	2 ³ / ₄ "	12 ¹ / ₄ "	6 ⁵ / ₈ "	18	KTS-003
KTS-524	20	11 ¹ / ₂ "	4 ¹ / ₂ "	16"	6 ⁵ / ₈ "	22	KTS-003
KTS-525	20	17 ¹ / ₂ "	9 ¹ / ₂ "	27"	7 ³ / ₄ "	35	KTS-005
KTS-526	24	11 ³ / ₄ "	3 ¹ / ₄ "	15"	7 ¹ / ₄ "	31	KTS-005
KTS-527	24	15 ³ / ₄ "	6 ¹ / ₂ "	22 ¹ / ₄ "	7 ⁷ / ₈ "	40	KTS-005
KTS-528	24	21 ³ / ₄ "	12"	33 ³ / ₄ "	9 ¹ / ₄ "	56	KTS-005

*Does not have a handle.

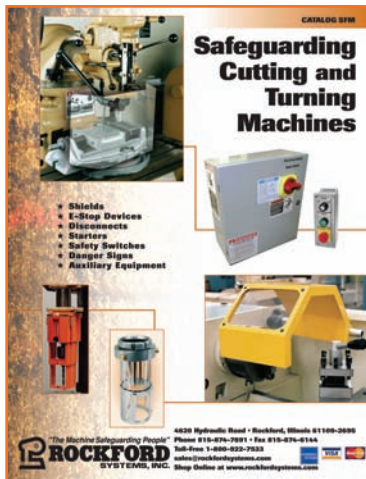

Safeguarding Cutting and Turning Machines

Catalog SFM

Features products and services for updating cutting and turning machines.

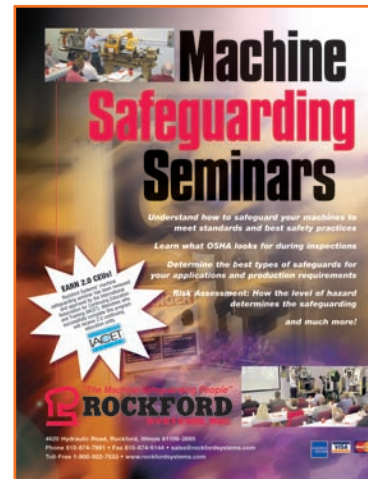

Machine Safeguarding Seminars
Catalog SEM

Provides details on our monthly machine safeguarding seminar.



Safety Switches, Relays, and Controllers

Catalog SS

Features safety switches, relays, timers, controllers, and more!

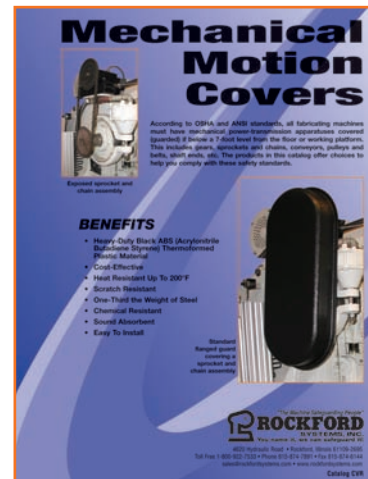

Mechanical Motion Covers (Guard/Covers)

Catalog CVR

Features products for covering gears, sprockets and chains, conveyors, pulleys and belts, and more!

www.rockfordsystems.com



4620 Hydraulic Road • Rockford, Illinois 61109-2695

Phone 815-874-7891 • Fax 815-874-6144

Toll-Free 1-800-922-7533

sales@rockfordsystems.com • www.rockfordsystems.com