

# Safety on Disc/Belt Sanders

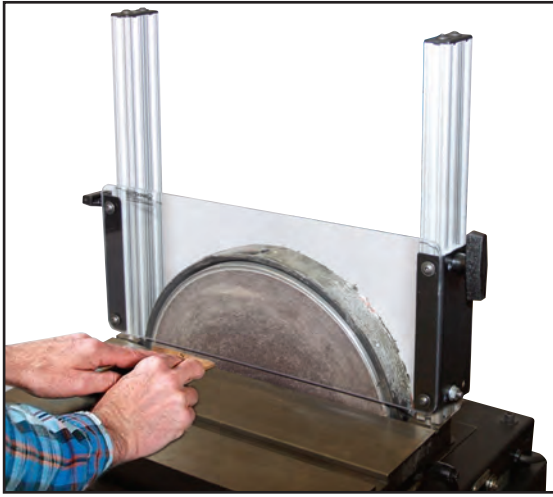

Disc sander shield assembly.

These high-quality, adjustable disc and belt sander shields place a barrier between an operator and flying debris generated at the point of operation. They fasten directly to the machine using 1" x 2" extruded aluminum with mounting hardware included. The transparent portion of the shield is constructed of high-impact-resistant,  $\frac{3}{16}$ "-thick clear polycarbonate. Easy vertical adjustment of the shields is achieved simply by loosening and tightening the black knobs.

These shields can also be used on a combination belt sander & disc sander.

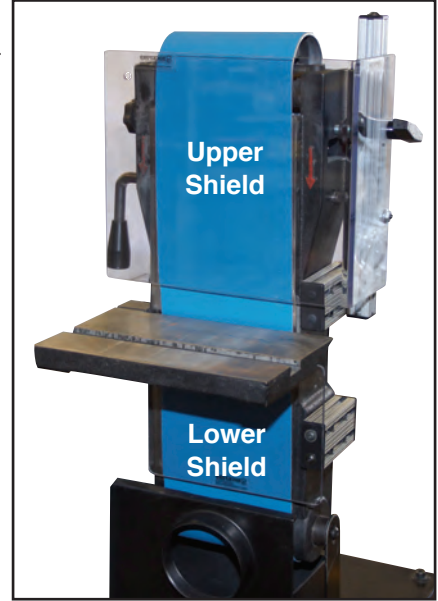

Belt sander shield assembly.



## Disc Sander Shield

| Part No. | Description  | Replacement Shield Part No. |
|----------|--|-----------------------------|
| KYL-228  | 9" Disc Sander Shield Assembly (6" X 13" Shield)   | KYL-229                     |
| KYL-230  | 12" Disc Sander Shield Assembly (7" X 16" Shield)  | KYL-231                     |
| KYL-232  | 16" Disc Sander Shield Assembly (9" X 20" Shield)  | KYL-233                     |
| KYL-234  | 20" Disc Sander Shield Assembly (11" X 24" Shield) | KYL-235                     |
| KYL-236  | 24" Disc Sander Shield Assembly (13" X 28" Shield) | KYL-237                     |

## Upper Belt Shield

| Part No. | Description                                  |
|----------|--|
| KYL-226  | Upper Belt Shield Assembly (L-Shaped Shield) |
| KYL-227  | Upper Belt Shield Only (L-Shaped)            |
| FKT-083  | T-Handle Knob                                |

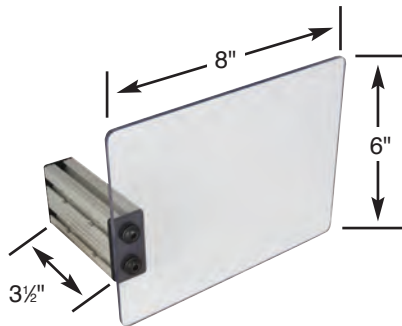
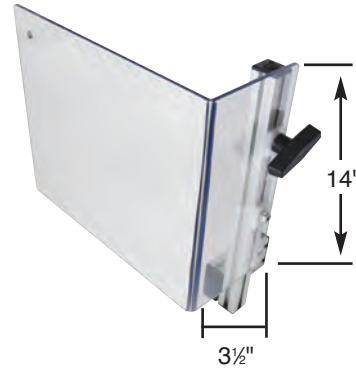

## Lower Belt Shield

| Part No. | Description                                 |
|----------|---|
| KYL-224  | Lower Belt Shield Assembly (6" X 8" Shield) |
| KYL-225  | Lower Belt Shield Only (6" X 8")            |



We recommend a Sensing-Saf-Start® or disconnect switch for all power-driven machines—see pages 64-69.